

iLIFT | XIZI

PASSENGER ELEVATOR

XIZI2103



 **Service Line / 400-826-1112**

XIZI ELEVATOR CO.,LTD.

Add/NO.2329 Science and Technology Av.,
Lin'an Economic Development Zone, Hangzhou, China
[Http://www.xizilift.com](http://www.xizilift.com)

This book is a publication of general information, and we reserve the right to alter the techniques and specifications of products at any moment.
The content of the brochure is for reference only, and the actual contract agreement between the two parties and the actual product shall prevail.

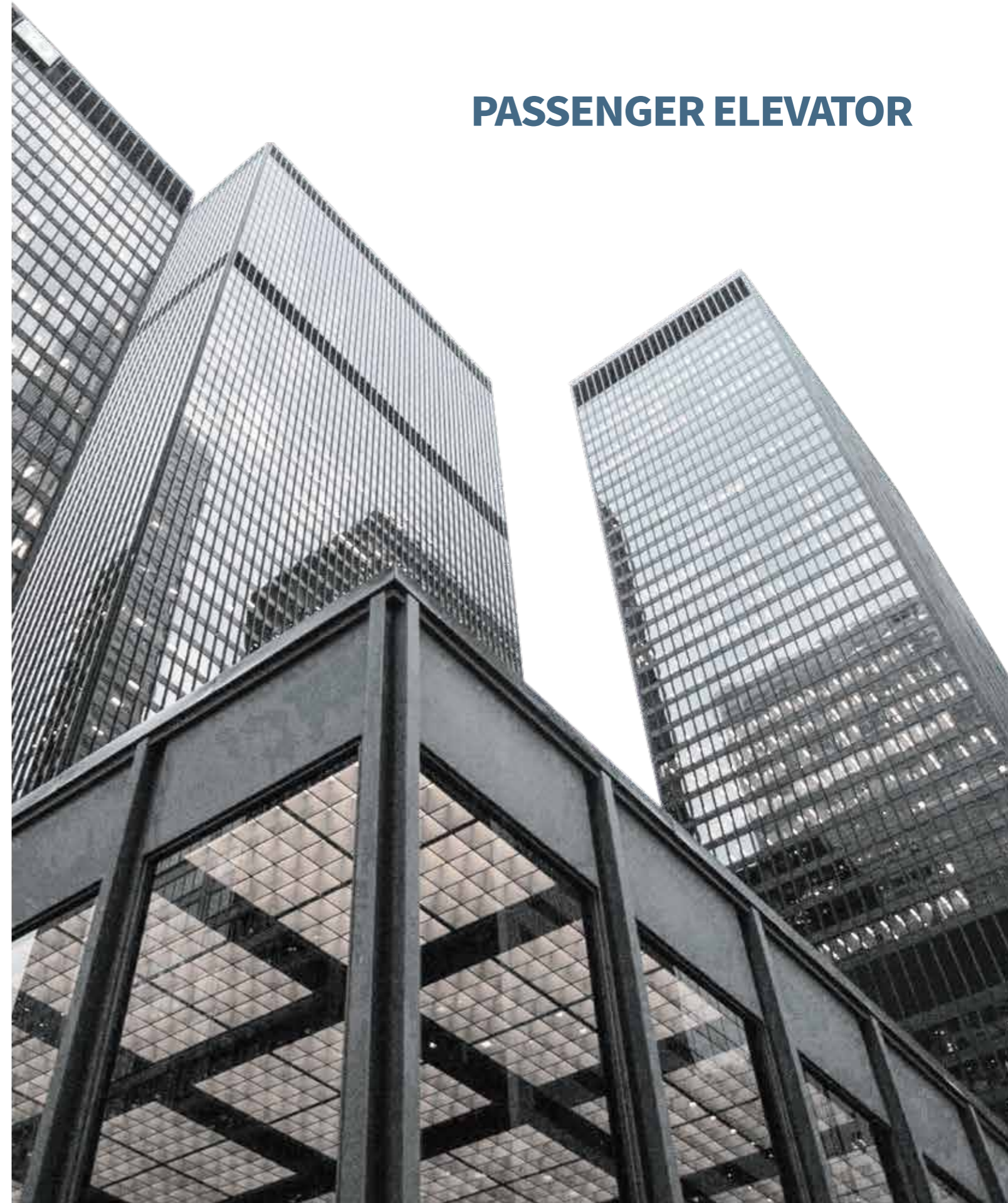

TOP 500

[subsidiary of China Top 500 Private Enterprises Leading equipment manufacturer]

China Top 500 Private Enterprises

About XIZI Elevator

XIZI Elevator Co., Ltd. is a modern comprehensive elevator enterprise integrating high-end R&D, sales, manufacturing, installation and after-sales service. The company inherits the successful experience of XIZI in the elevator industry for nearly 40 years, always insists on independent innovation and independent production, has a strong research and development strength and a complete product system. The marketing network covers the world, and the industry-leading brand has been created with the business philosophy of cooperation over competition, unparalleled technical advantages, and complete sales and service network.

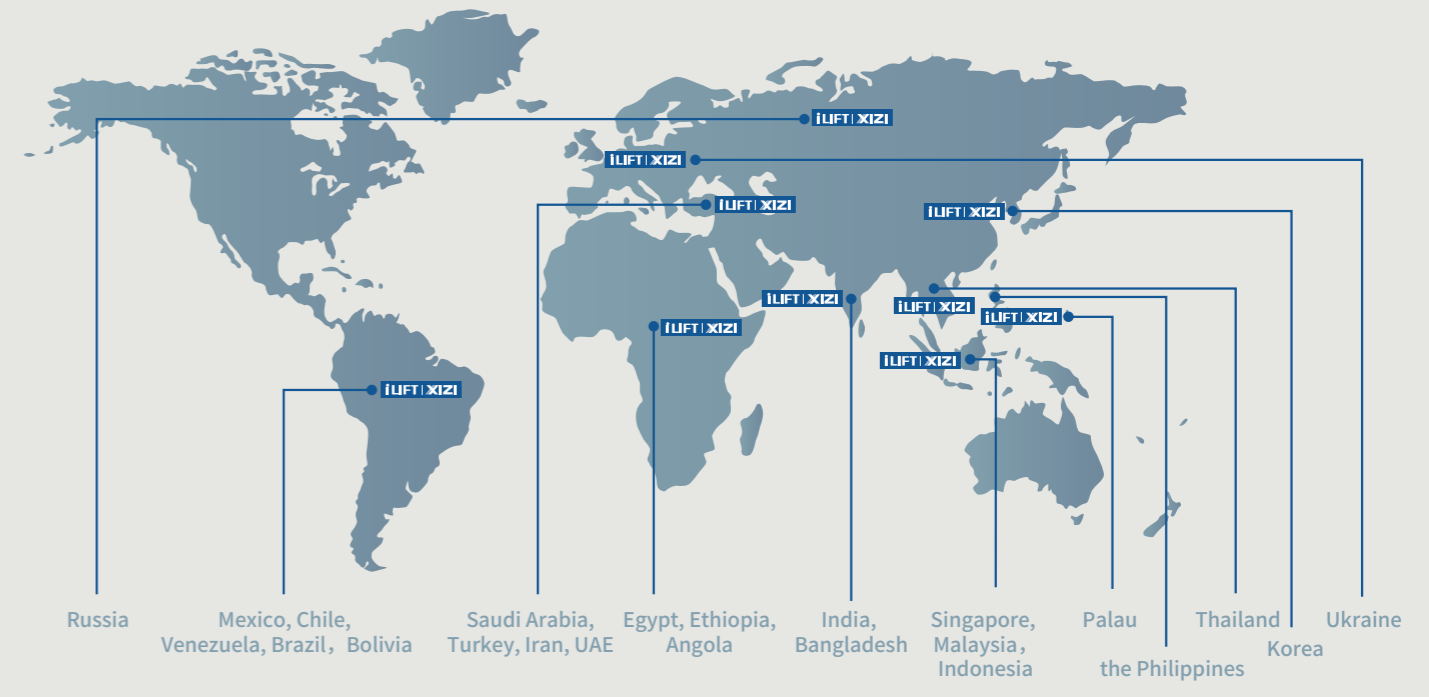

FORGE AHEAD FOR 40 YEARS



1981

XIZI Elevator Factory was established in Hangzhou



1987

Installation license obtained



1993

The first elevator exported to Vietnam by XIZI



2007

Elevator components of XIZI ranked Top1 in China



1997

XIZI OTIS Elevator Co., Ltd. was established



1996

XIZI Elevator installed 4 escalators for Hangzhou Department Store



2008

XIZI:UNITE Elevator Co., Ltd. was established



2013

Sales network covers more than 60 countries and regions around the world, 34 branches and 28 offices in China



2015

Lin'an factory of XIZI LIFT has been put into operation



2021

XIZI 西子电梯

The 40th Anniversary of XIZI Brand



2020

The annual orders exceeded 30,000 sets



2018

Launch intelligent brand "iLIFT"



2016

XIZI 西子电梯

XIZI brand returns

ELEVATOR CONFIGURATION

The types of Xizi Elevator technology products fully cover the demands of users, creating unlimited possibilities for construction transportation.

Passenger elevator with machine room UN-Victor series

XIZI UN-Victor, with environmental protection, unparalleled safety and comfort, energy saving, provide enjoyable experience to the modern urbanism, it's favourable in the market.

Main configuration

Capacity	630kg~1600kg
speed	1.0m/s~2.5m/s
Traction machine	Vito/GETM
Door operator	Jarless-con
Controller	U-CON
Door protection	Light curtains

Passenger elevator machine room-less UN-Victor MRL series

Compared with traditional elevators, XIZI UN-Victor mrl machine room-less elevator saves the space occupied by the machine room, maximizes the space saving for customers and creates value.

Main configuration

Capacity	630kg~1600kg
speed	1.0m/s~1.75m/s
Traction machine	Vito/GETM
Door operator	Jarless-con
Controller	U-CON
Door protection	Light curtains

Passenger elevator machine room-less G3 (Steel lift)

XIZI G3, with its advanced technology, high efficiency, energy saving, safety and intelligence, creates more value for high-class residences, office buildings, and luxury hotels.

Main configuration

Capacity	400kg~1600kg
speed	1.0m/s~1.75m/s
Traction machine	Vito/GETM
Door operator	Jarless-con
Controller	U-CON
Door protection	Light curtains

Panoramic elevator UN-Grace

XIZI UN-Grace is a perfect combination of artificial intelligence. In the space flowing up and down, you can appreciate the beautiful scenery of the building and enjoy the comfort brought by modern equipment.

Main configuration

Capacity	800kg~1600kg
speed	1.0m/s~1.75m/s
Traction machine	Vito/GETM
Door operator	Jarless-con
Controller	U-CON
Door protection	Light curtains

▶ Traction machine

Note: the pictures are for reference only, and follow the elevator configuration

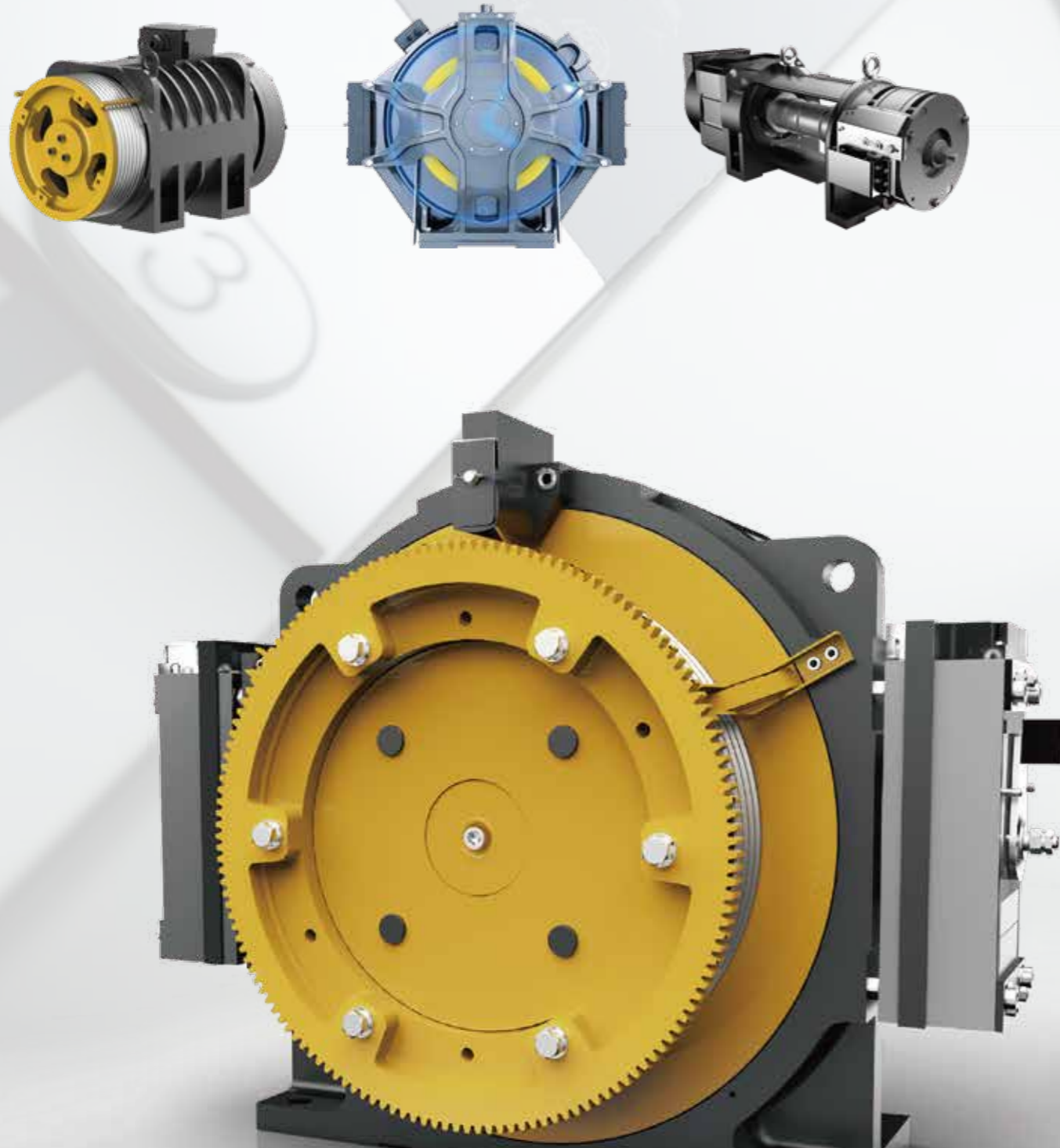

XIZI is a hi-tech enterprise with independent R&D ability and we have our own factory and brand

ENERGY SAVING AND ENVIRONMENTAL PROTECTION

Feel the efficient and stable operation of the elevator with a green vision, and enjoy a spiritual journey of space.

▶ Energy saving traction machine



● Environmental protection

The permanent magnetic synchronous gearless traction machine adopts an outer rotor structure, a permanently sealed bearing with low noise, no need to replace grease, and no oil pollution. And no maintenance is required, saving maintenance costs for users.



● Stable, reliable

The permanent magnetic synchronous motor adopts high temperature resistant rare earth materials, and is equipped with a motor overheating protection device to ensure that the motor will never demagnetize; the double stack brake is sensitive and has a large braking force to ensure the safety of passengers.



● Space-saving

The permanent magnetic synchronous gearless traction machine is small in size and compact in structure, which can fully meet the design of small machine room elevators, thereby effectively saving building space.



● Energy efficient

Compared with the geared mainframe, the reduction box is eliminated, the mechanical energy consumption, noise and vibration caused by this are eliminated, and the transmission efficiency is greatly improved. Compared with the traditional geared mainframe, the average energy saving can reach 30%.

► Lighting system



Using LED light source, energy saving and environmental protection.



It adopts voltage and current overload protection technology, which is safer and more energy-saving. Compared with incandescent lamps, it can save energy by more than 80%.



The car lighting and fan are equipped with automatic switch functions. When someone is called—automatically start; intelligently judged that no one is called—the car lighting and fan are automatically turned off. Let the elevator achieve high efficiency, energy saving and continuous standby.

► ISO energy efficiency standard TUV certification

ISO energy efficiency standard TUV certification ISO 25745 is an international rating standard for elevator energy consumption.

UN-Victor series has obtained TUV certification for ISO 25745 energy efficiency rating. Reach the highest level A.

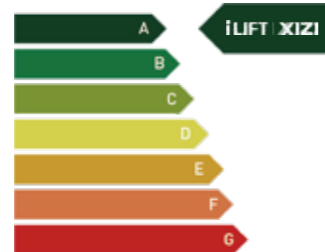

► Energy regeneration system (optional)

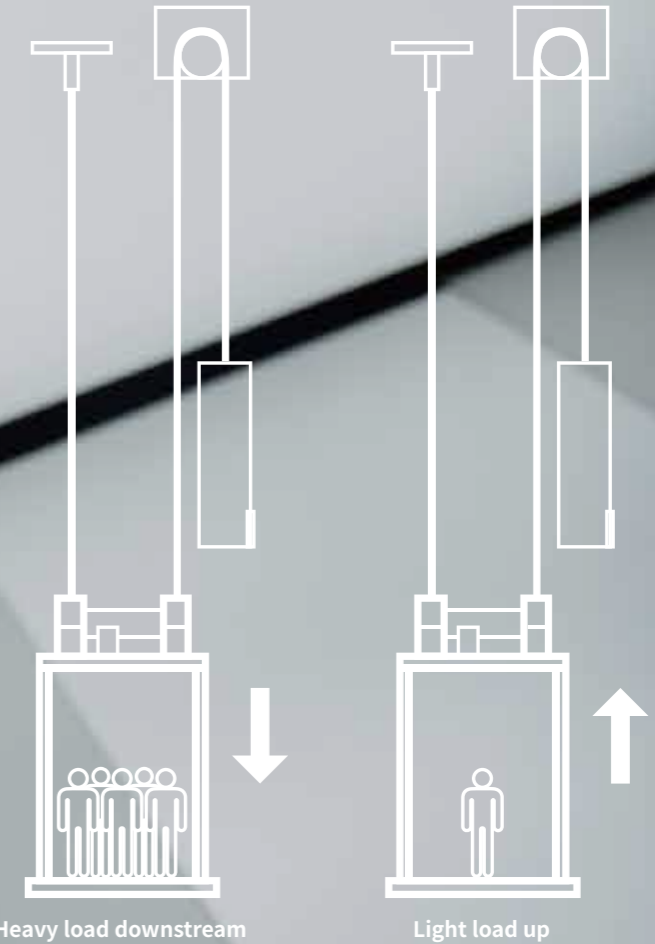

Through the energy regeneration system, the energy generated when the elevator is fully loaded down or lightly loaded is converted into electrical energy and fed back to the grid for use by the equipment under the grid

COMFORTABLE ENJOYMENT

Let every encounter be a mark of every time, and make comfort a different experience for you.

► Control System

Independent R&D, with our own factory and brand

More efficient

With dual 32-bit CPU, the control and drive are closely coordinated to make the elevator run more efficiently.

More value

U-Con system integration is higher than that of ordinary systems, reducing the volume of the control cabinet and improving the utilization rate of the building.

Easier to maintain

The system function software is installed in a modular design, and the functions are clearly defined, which is convenient for debugging and maintenance.



Note: This picture is UN-Victor mrl series controller

► G3 exclusive steel belt

G3 adopts the latest imported composite steel belt to replace ordinary steel rope. Let passengers enjoy the comfortable ride experience.

More secure

The safety performance of the composite steel belt is much higher than that of the steel rope, and each steel belt can withstand up to 40KN tension. And passed more than a dozen rigorous performance tests.

More durable

The life of composite steel bars is 2 to 3 times longer than that of traditional steel ropes.

More comfortable

The flexibility of composite steel bars is much greater than that of steel wire ropes, so it greatly reduces vibration during operation. The vibration generated during the trip creates a quiet and comfortable ladder environment for users.

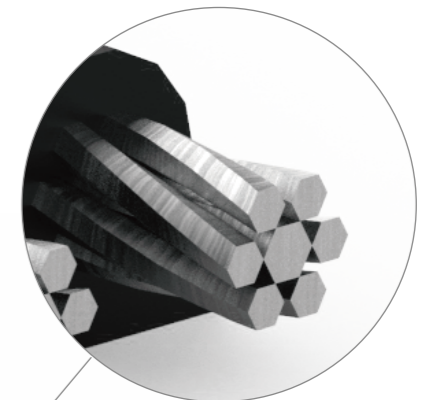

SAFETY & EASE

Every meeting is to escort you, and build trust every time with the most reassuring service.

► Security guard

● Light curtain door protection

Light curtains with standard 154 beams, 40 pairs of original light sensors are used, and the distance between the sensors is shortened by 45mm, which greatly improves the sensitivity of foreign object detection and enhances the safety of taking the elevator. The protection level of the light curtain is IP65.

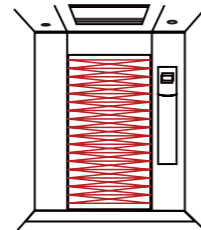

● Anti-scratch door function

Equipped with a professional anti-scraping door device to prevent passengers from opening the door from the inside of the car when the elevator stops on a non-leveling floor caused by accidents such as failure or power failure, and eliminates all potential safety hazards.



● Reset rescue function

When the elevator position is lost, it will automatically enter the reset rescue mode and run to the nearest floor, open the door to release the passengers, and then run to the base station to reset.



● Adaptive speed limit control

When the three-phase power supply has undervoltage, overvoltage, overcurrent, etc., the elevator speed will automatically drop to 60% of the rated speed, and run at a safe speed to the nearest floor to stop, ensuring that passengers can take the elevator safely.



● Voice clam

Auto playing a voice when elevator emergency stop by fault, let the passenger calm down and waiting for rescue. Extra voice reminding during the running, guide the passenger safety loading.



● Steel belt safety monitoring device

24-hour intelligent detection of steel core metal fatigue and strand damage, instead of visual monitoring, intelligent analysis of steel strip quality, the elevator will stop for self-protection when necessary. Once the bending times upto 90% of lift span or the service life is less than three months, it will automatically remind to replace the steel belt.

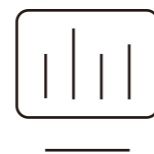

SCIENTIFIC TECHNOLOGICAL

Travel with technology, awaken the sense of space, and deliver the lean of the brand with the ladder of wisdom.

● SMS alarm (optional)

When the elevator fails, the SMS alarm device actively sends a short message to the maintenance personnel to give an alarm, obtain the failure information in time, and improve the rescue efficiency.



● Virtual voice assistant(optional)

The user realizes functions such as floor registration and door opening and closing through voice. The wake-up rate and recognition accuracy rate in noisy environments is over 95%, and in quiet environments it is over 99%.



● Intelligent face recognition call system (optional)

When the passenger is within a certain sensing range, the recognition system will automatically call the camera to quickly collect facial information; through single and binocular live detection to avoid fraud information, the elevator door can be opened after successful comparison.



● QR code smart call (optional)

With the help of the QR code intelligent connection control system, it is convenient for administrators and users to realize elevator unlocking, permission control, elevator calling, APP to register floors and other functions.



● Floating button (optional)

The floating button device can project the interface in the air and directly image, and does not rely on other physical display. The user can directly operate the elevator buttons in the air. There is no physical contact during the interaction process, which effectively avoids cross-infection; the interactive response is sensitive and the imaging is with a sense of technology, stable, safe and reliable during use.



PASSENGER ELEVATOR DECORATION

Spatial design
 Highlight the architecture
 Shine the choice
 Enrich the spatial imagination
 Enjoy the trip



U-CR126 (STANDARD)







Ceiling: U-CL046
 Floor: U-FL012



U-CR126



Option

	<p>U-CR126(STANDARD)</p> <p>Ceiling: Hairline stainless steel+Acrylic +Downlight (integrated ceiling) U-CL046 Rear wall: Hairline stainless steel Side wall: Hairline stainless steel Floor: PVC(U-FL012)</p>		<p>U-CR130</p> <p>Ceiling: Hairline stainless steel+LED downlight (ceiling integrated with car top) U-CL088 Rear wall: Decoration film steel plate + Mirror stainless steel Side wall: Hairline stainless steel + Mirror stainless steel Floor: PVC(U-FL012)</p>
	<p>U-CR147</p> <p>Ceiling: Pearlescent silver spray powder frame + Acrylic (U-CL095) Rear wall: Hairline stainless steel Side wall: Hairline stainless steel Floor: Spliced PVC(U-FL071)</p>		<p>U-CR028</p> <p>Ceiling: Painting steel frame + Acrylic (ceiling integrated with car top) U-CL054 Rear wall: Hairline stainless steel+ Mirror stainless steel etching (HM-96 Horizontal stripes) Side wall: Hairline stainless steel + Mirror stainless steel Handrail: Round stainless steel U-HR001 Floor: PVC (U-FL037)</p>
	<p>U-CR078</p> <p>Ceiling: Hairline stainless steel + Acrylic +LED down light (U-CL064) Rear wall: Hairline stainless steel+ Hairline stainless steel strip + Mirror stainless steel Side wall: Hairline stainless steel+ Hairline stainless steel strip + Mirror stainless steel Skirting: Hairline stainless steel Floor: PVC (U-FL046)</p>		<p>U-CR114</p> <p>Ceiling: Hairline stainless steel + Acrylic U-CL080 Rear wall: Hairline stainless steel+ Hairline stainless steel moulding + Mirror stainless steel Side wall: Hairline stainless steel+ Hairline stainless steel moulding + Mirror stainless steel Handrail: Round mirror stainless steel Floor: PVC (U-FL031)</p>

Ceiling

Integrated ceiling



U-CL046(STANDARD)

Ceiling material:
Hairline stainless steel+ Acrylic+LED light



U-CL029

Ceiling material:
Hairline stainless steel+ Acrylic+LED light



U-CL038

Ceiling material:
Hairline stainless steel+ Acrylic+LED light source



U-CL037

Ceiling material:
Hairline stainless steel+ Painting steel
+ Acrylic+LED down light



U-CL030

Ceiling material:
Hairline stainless steel+ LED down light



U-CL028

Ceiling material:
Hairline stainless steel+ Acrylic+LED light



U-CL021

Ceiling material:
Painting steel frame+ Acrylic



U-CL041

Ceiling material:
Painting steel + Arched aluminum
composite panel + Mesh plate

Split ceiling

Floor

PVC



**U-FL012
(standard)**



U-FL026



U-FL010

Marble



U-FL060



U-FL011



U-FL006

► Interface

Break the limit of time
 Encounter with technology
 Meet with art
 Between square inches
 Connect you to the world

COP & Display

► Display

◉ Standard



6.4"iLED

◉ Option



Dancing 7" TFT



Charming 7" TFT



Dancing 10.4\12.1" TFT



Charming 10.4\12.1" TFT



Fantasy 18.5" TFT



Spring 18.5" TFT



Comely 18.5" TFT



Standard
 Integrated COP
 U-CY 100
 Material:
 Hairline stainless steel



Option
 Separated COP
 U-CF 1200
 Material:
 Hairline stainless steel

► Button

◉ Standard



iBS34M(BL)

Type: hairline stainless steel/mirror stainless steel/titanium stainless steel braille button

◉ Option



iBR34M(BL)

Type: hairline stainless steel/mirror stainless steel/titanium stainless steel braille button



BR34C

Type: hairline stainless steel/mirror stainless steel/titanium stainless steel button



XBR27D

Type: hairline stainless steel/mirror stainless steel/titanium stainless steel button

The renderings are for reference only, and the actual product shall prevail

HOP

Standard



U-ZW1600

Material: hairline stainless steel
Display type: 4.3" iLED display



Button standard:
Type: iBS34N(B)
Type: hairline stainless steel
braille button



Button standard:
Type: iBR34N(B)
Type: hairline stainless steel
braille button

Option



U-ZY500

Material: hairline stainless steel
Display type: 4.3" iLED display



The night
U-ZW3400-A



Daytime
U-ZW3400-B



Sunrise
U-ZW3400-C



Sunset
U-ZW3400-D

U-ZW3400

Material: glass
Display type: 4.3" iLED display
Button type: mechanical button

Horizontal Display



U-HW100(bottomless box)

Panel material: hairline stainless steel
Display :7" BND



U-HW200(bottomless box)

Panel material: hairline stainless steel
Display :7" BND

Handrail



U-HR001

Round stainless steel



U-HR003

Round mirror stainless steel



U-HR004

Flat stainless steel

Landing Light



U-LY100-A

Material: hairline stainless steel
Titanium mirror stainless steel (optional)
White mirror stainless steel(optional)
landing light: Acrylic
Color: up-green, down-red



U-LY100-B

Material: hairline stainless steel
Titanium mirror stainless steel (optional)
White mirror stainless steel(optional)
Arrival light: Acrylic
Color: up-green, down-red

PANORAMIC ELEVATOR DECORATION



U-CR904 (STANDARD)

Ceiling: hairline stainless steel+downlight(U-CL097)
 Front wall: hairline stainless steel
 Car panel: hairline stainless steel+ laminated glass (5+5)
 Handrail: mirror st. steel round handrail (U-HR020)
 Floor: PVC (U-FL012)

Option



U-CR919-3

Ceiling: hairline stainless steel+LED downlight(U-CL097)
 Front wall: hairline stainless steel + laminated glass
 Car panel: hairline stainless steel+ laminated glass (5+5)
 Handrail: mirror st. steel round handrail (U-HR020)
 Floor: PVC (U-FL012)



U-CR920

Cover: hairline st. steel +acrylic
 Ceiling: baked steel(aurora silver)+acrylic+LED downlight (U-CL109)
 Front wall: hairline stainless steel
 Car panel: hairline stainless steel+ glass
 Handrail: mirror st. steel round handrail
 Floor: PVC



U-CR909-1

Cover: baked steel +acrylic
 Ceiling: baked steel+acrylic (U-CL098)
 Front wall: hairline stainless steel
 Car panel: hairline stainless steel+ glass
 Handrail: mirror st. steel round handrail (U-HR022)
 Floor: PVC (U-FL012)



U-CR922

Cover: titanium st. steel + acrylic
 Ceiling: baked steel(flash silver titanium YM-04)+ acrylic+LED light (U-CL111)
 Front wall: titanium st. steel
 Car panel: titanium st. steel +titanium etched mirror st. steel +glass
 Handrail: titanium hairline st. steel flat handrail +titanium mirror st. steel bracket (U-HR030)
 Floor: marble (U-FL075)



U-CR901-1 (STANDARD)

Ceiling: hairline stainless steel +downlight (U-CL097)
 Front wall: hairline stainless steel
 Car panel: hairline stainless steel+ glass (5+5)
 Handrail: mirror st. steel round handrail (U-HR020)
 Floor: PVC (U-FL012)

Option



U-CR901-2

Cover: hairline stainless steel
 Ceiling: painting steel(aurora silver)+acrylic (U-CL021)
 Front wall: hairline stainless steel
 Car panel: hairline stainless steel+laminated glass (U-HR001)
 Handrail:round stainless steel
 Floor: PVC (U-FL012)



U-CR914

Ceiling: hairline stainless steel +acrylic (U-CL103)
 Front wall: hairline stainless steel
 Car panel: hairline stainless steel+laminated glass
 Handrail: round mirror stainless steel
 Floor: PVC (U-FL012)



U-CR917

Cover: hairline stainless steel rose gold plated + mirror stainless steel rose gold plated strip + crystal acrylic light bar
 Ceiling: Hairline stainless steel rose gold plated + mirror stainless steel rose gold plated + acrylic (U-CL106)
 Front wall: hairline stainless steel rose gold plated + laminated glass
 Car panel: hairline stainless steel rose gold plated + mirror stainless steel rose gold plated + laminated glass
 Handrail: hairline stainless steel rose gold plated flat handrail + mirror stainless steel rose gold plated floor stand (U-HR027)
 Floor: marble



U-CR918

Cover: mirror etched stainless steel (HM-95)
 Ceiling: mirror stainless steel frame + acrylic + LED downlight (U-CL107)
 Front wall: mirror stainless steel
 Car panel: mirror stainless steel + laminated glass (outsourcing mirror stainless steel)
 Handrail: mirror stainless steel round tube floor handrail (U-HR022)
 Floor: PVC (U-FL013)



U-CR912 (STANDARD)

Ceiling: hairline stainless steel +acrylic (U-CL101)
 Front wall: hairline stainless steel
 Car panel: hairline stainless steel+glass
 Handrail: round mirror stainless steel
 Floor: PVC (U-FL012)

INTERFACE

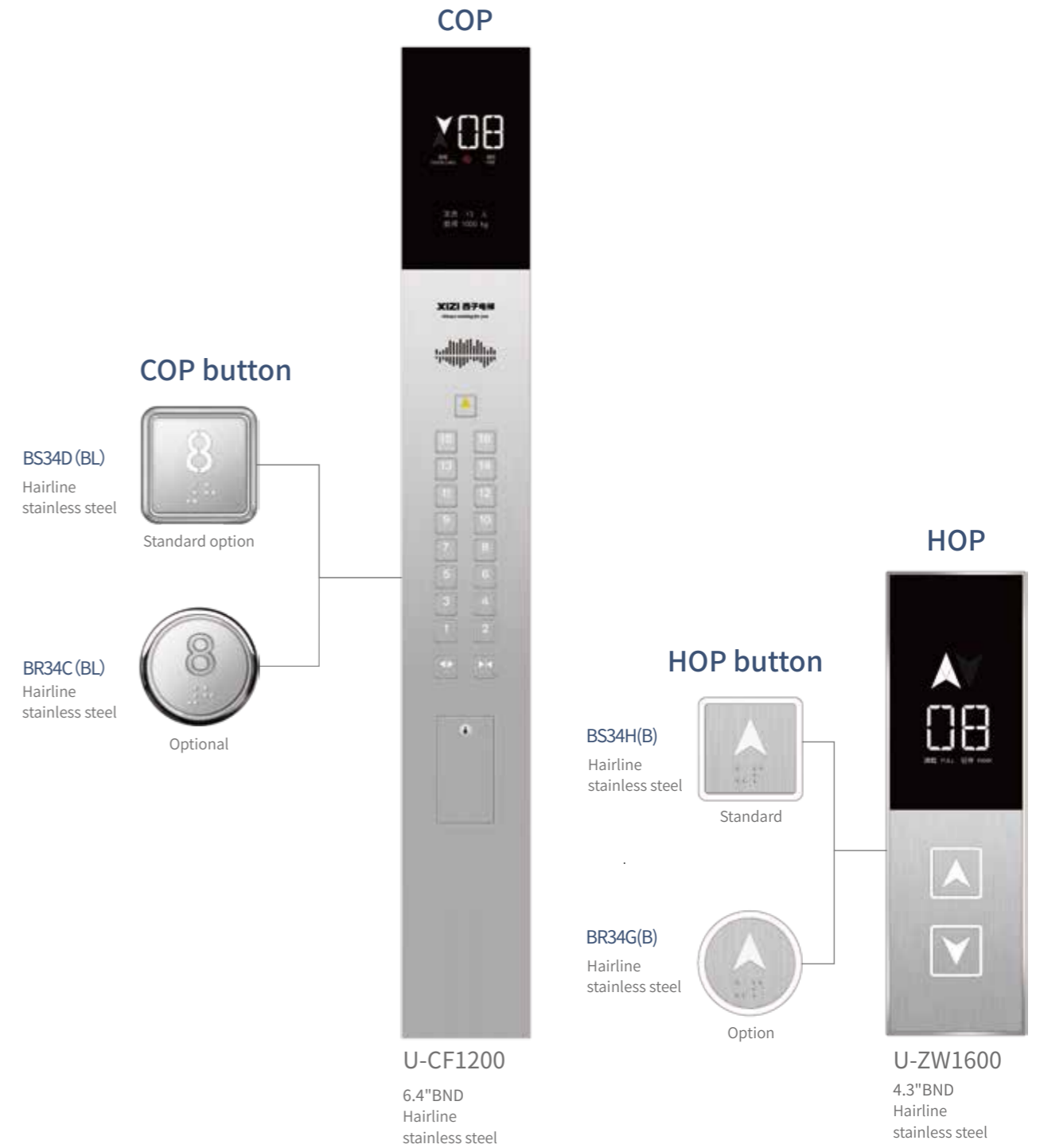

OPTIONAL ETCHING

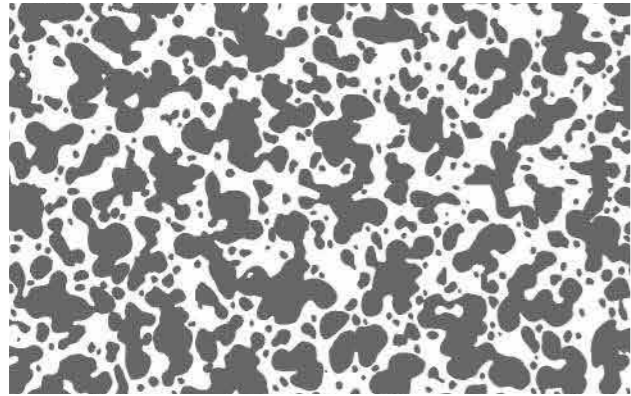

■ convex □ concave

XIZI - 04

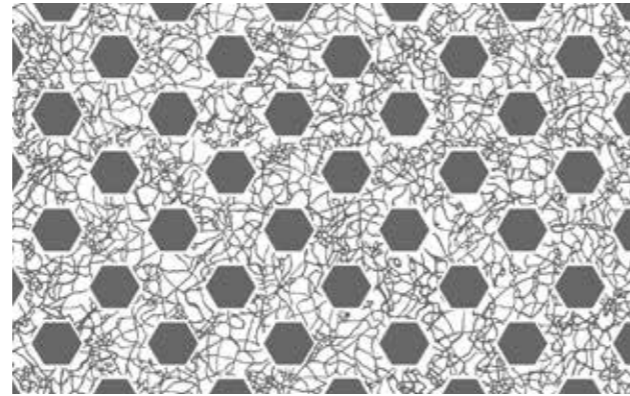

■ convex □ concave

XIZI - 10

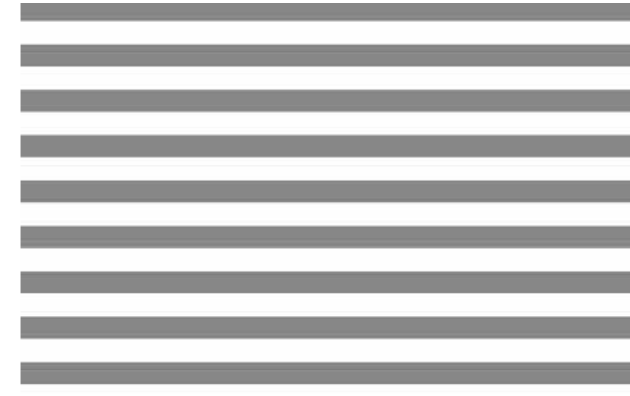

■ convex □ concave

XIZI - 81(Horizontal)

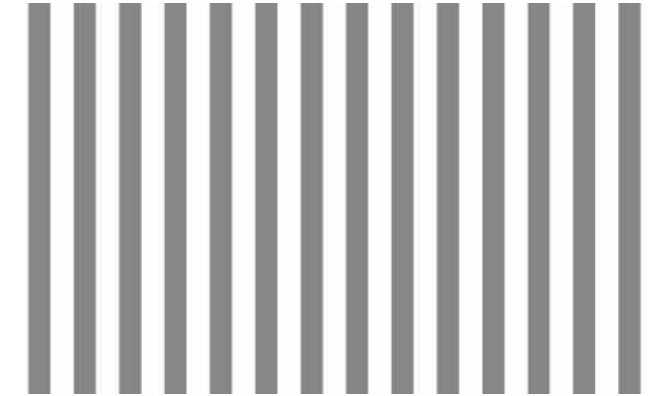

■ convex □ concave

XIZI - 81(Vertical)

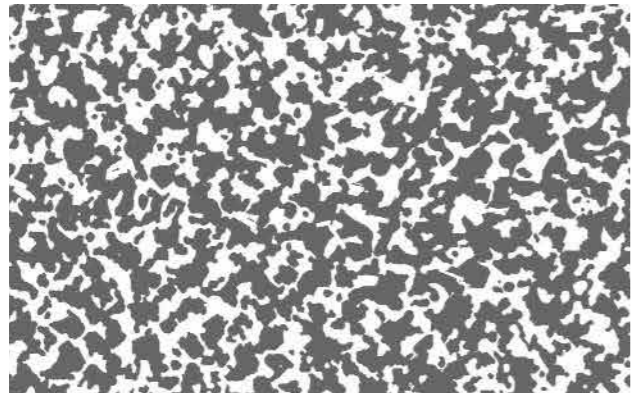

■ convex □ concave

XIZI - 37

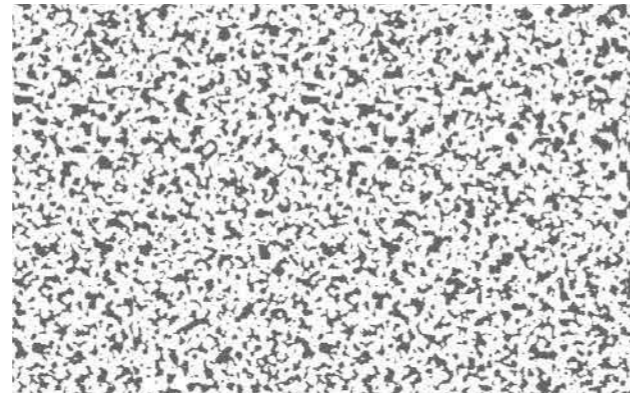

■ convex □ concave

XIZI - 40

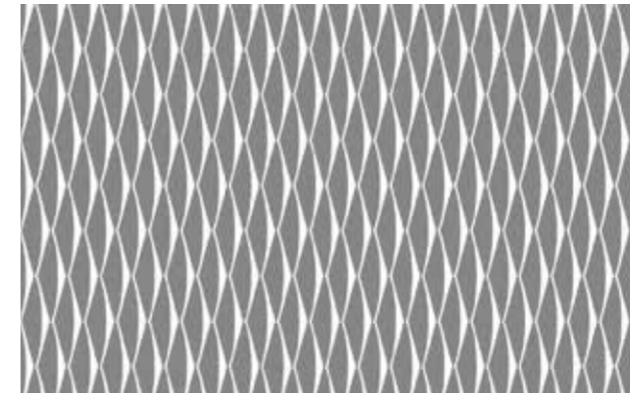

■ convex □ concave

XIZI - 89



■ convex □ concave

XIZI - 90

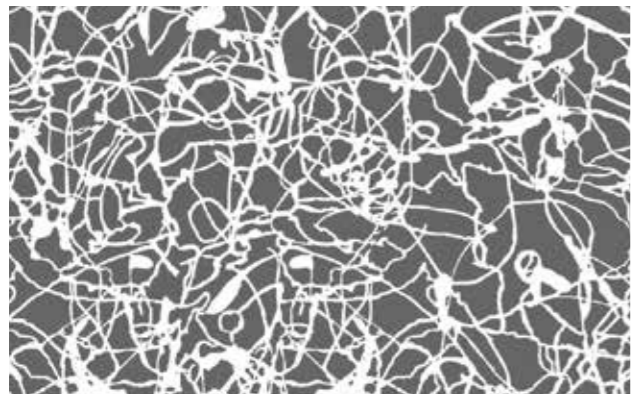

■ convex □ concave

XIZI - 75

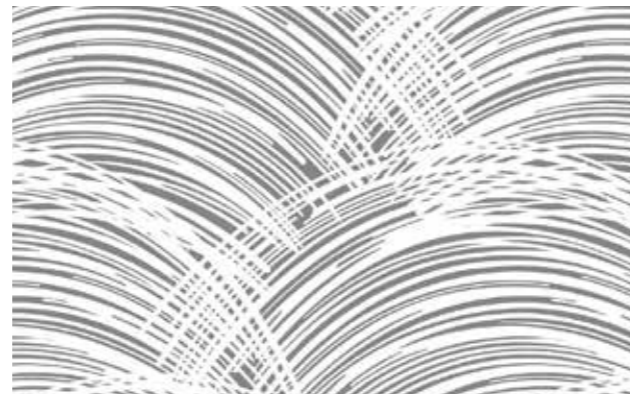

■ convex □ concave

XIZI - 76

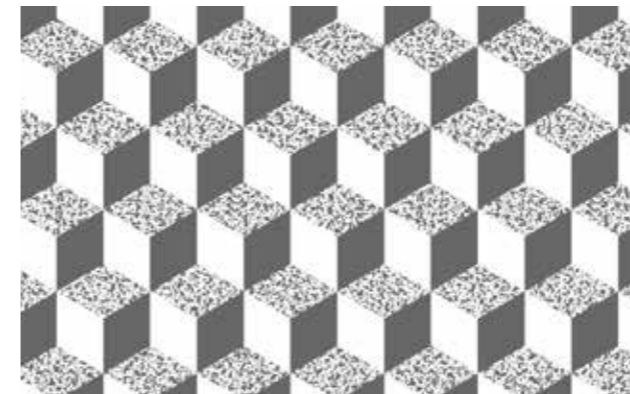

■ convex □ concave

XIZI - 105

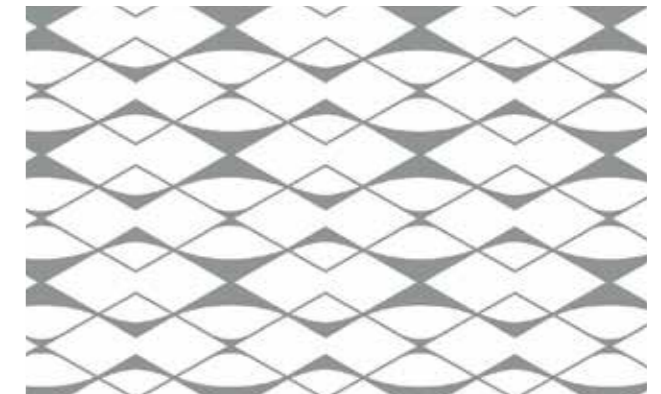

■ convex □ concave

XIZI - 15

FUNCTION LIST

● Standard
○ Option

► Safty For Passenger

Function	Description	Remarks
Light Curtain Protection	Light Curtain acts if there is any obstruction between door panels. The door will be reopened. This function will not be available during fireman's operation. Class of light curtain protection: IP 65.	●
ANS-Anti-Nuisance Car Call Protection	If there is only one passenger in the car, and an excessive number of calls are registered, nuisance is detected and all car calls will be cancelled, requiring registration of proper of calls.	●
LNS-Load Non Stop	When a car is loaded to predetermined percentage of its capacity, it is considered "full". The car will bypass further hall calls. Additional passengers would be unable to enter.	●
LWS-Overload Protection	If the load exceeds the rate load, the sound signal will be given out by speaker, and "OVERLOAD" will be displayed, the car door will not close, the elevator will not start.	●
Button Anti-adhesion Protection	If adhesion on a button due to mechanical fault, elevator will shield the button and no longer respond the order from this button.	●
Door Closing Torque Protection	Door operator had set the closing torque, in case of jamming over the torque, the door will not close by improving the torque.	●
ELTU-Emergency Light	Emergency light in the car will start whenever there is power cut.	●
ALARM-Alarm Bell	An alarm sound signal will be given out to the outside in specific conditions.	●
DTC-Door Time Protection Close	If the car door does not close completely within an adjustable time after the door close command, after three unsuccessfully retries, the elevator will automatically enter protection state. When normal door closing is detected, elevator will recover to normal running.	●
DTO- Door Time Protection Open	If the car door does not open completely within an adjustable time after the door open command, car call and hall call signals will be automatically cancelled, and elevator will stop at the next floor and open its doors.	●
Door Panels Forced Closing Upon Gravity	If hall door connecting wires fails, gravity will force the main panel and auxiliary panel closed.	●
Mechanical Stop For Landing Door Forced Opening	The function is to protect the person outside the landing door in case that the wire rope of landing door brakes.	●
NTSD-End Protection	Both upper and lower terminal of elevator are equipped with terminal speed reducing switch, if the speed is not slowed to the pre-set value while the car reach the end floor, a forced deceleration will be carried out by system in order to protect the safety of the car.	●
EFO-Emergency Fireman Operation	fireman's service, a car shall return non-stop to the designated return landing and park with doors fully open.	●
Fire Feedback	When fireman operation finished, a signal will be feedback to facilitate access to building system.	●

Local Leveling	If accidental fault occurs on elevator, current floor will be memorized, so that for recovery it's no need to return to terminal landing, improves running efficiency.	●
Door Opening Prohibition Outside Door Zone	For safety, door opening is disabled outside door zone.	●
Fault Self-Diagnosis	When control circuit abnormal is detected, automatic stop the elevator to ensure the safe of passenger.	●
Fire Display	There is display inside of the car when the list enter into fireman operation.	●
ARD-Automatic Rescue Device	This device is used for rescue operation in case of power shutdown, it is powered by a rechargeable battery, when a sudden power cut happens, the car will move towards to the near floor, keep the door open to the passenger.	○
Earthquake Operation	With this function, in case of earthquake, earthquake detector acts and inputs signal to control system which drive elevator to near floor, open door to release passengers and stop.(Earthquake detector shall be solved by customer)	○
Core Closing Anti-stall Function	When elevator stops, it will start core closing circuit. During current producing for cutting line of magnetic force of permanent magnet, opposite torque is produced to avoid stall due to braking failure.	○
Light Sensor And Safety Edge Protection	Light sensor and mechanical safety edge can be option.	○
ACP-Anti Crime Protection	Anti-Crime Protection forces each car in the group to stop at pre-determined floor and open its door. This allows a security guard at the floor to visually inspect the passenger of the elevator before the car completely its run.	○
EFS-Emergency Fireman's Service	EFS shall automatically place the car on independent service when the pre-set key is started, all calls cancelled, only answer the car call inside to cooperate the fireman, this function need to match with the fire lift.	○
Password Floor Service	The special floor can be set the password through the button in car.	○
EPO-Emergency Power Operation	In case that regular power supply shuts down, the power supply of cars turns to Emergency Power, then cars in group except cars in inspection mode run to defined landing (or next landings) one by one. After arrival to rescue position, the cars open doors and let passengers out. It's available to define a part of cars in group for normal service during EPO which is needed by some users. The return to full normal operation is done automatically when regular power supply is reestablished.	○

► Basic functions

Function	Function	Remarks
Floor Display	There is arrow display in COP and HOP to show the running direction to passenger.	●
FCL-Full Collective Operation	All car and/or hall calls registered are answered in the order in which the landings are reached. Direction of travel will be established by the first car command/ hall call registered. All calls on its way will be served, irrespective of the time sequence in which the calls were registered.	●
ATT-Attendant Service	The attendant operation feature allows semi-automatic operation with manual control through the switch in COP.	●
Attendant Bypass	In state of attendant operation, if the button NSB in COP is pressed, elevator will not answer to hall call and directly run to destination floor.	●

Reminding for Attendant	When hall call is registered under ATT, corresponding command lamp will flash to remind attendant to learn situation of such registered. The function acts together with ATT.	●
VIP Independent Service	This function is designed for meeting VIP' S special needs. When switched on independent service the elevator will only answer the registered car call, regardless of the hall calls while opening or closing the door by manual control and operating according to VIP' s registered signals.	●
CBC-Cancel Error Calls	Before the car starts, the registration of a car or operation can be cancelled by double click of this button. After the car starts, registration cancel will not allowed for the sake of passengers safety. The function can be made available by parameter setting.	●
Automatic Elimination Of Reverse Command	When the first or last landing is reached and elevator has to reverse, all commands originally registered will be eliminated.	●
Door Re-opening	During normal door closing, when car button that indicates the direction consistent to current running direction is pressed in hall, door will be re-opened.	●
DHB-Door Hold Button	Can adjust the door open time through the DHB on the COP when need to hold the door opening.	●
Locking At Main Landing	When locking switch is set, elevator back to main landing, stop using.	●
Braille Button	Push button with braille, convenient for blind.	●
Car Arrival Gong	During speed reduction and leveling, arrival gong on car top sounds to inform passenger and waiters of leveling and arriving.	●
Automatic Return To Main Landing	With this function, when there is no order or calls, after a period of time the elevator will automatic return to the main landing.	●
DOB/DCB –Door Open /Close Button	The door open/close button in car operation panel permits to open/close an automatic door, and keep it open/close by constant pressure.	●
DOB/DCB –Door Open /Close Button Light	Door open/close button will be highlighted if the buttons are pressed.	●
Separate Control DHT Of Car And Landing Door	The waiting time caused by hall call is longer than car call according to statistics, this function to improve the efficiency through independent adjust the door open holding time.	●
ADC-Advanced Door Closing	When the door is fully open and under the door hold period on normal running, push the door close button can close the door in advance.	●
Voice Calm	Overtime, overload, fireman operation, and leveling to nearest floor under fault, or open/close the door, automatic voice announcement will be played on calm and guide the passenger.	●
ADO-Advanced Door Opening	In order to accelerate traffic, automatic door opening starts while the elevator car approaches a landing.	●
Torque Compensation On Starting	To make the elevator more comfortable, system calculator the load in car, optimize it through compensating the torque on starting.	●
Digital Display In Car And Hall	16 digital display to show the position of elevator in COP and HOP.	●

LED Display In Car	Car display is LED.	●
DHB-Door Hold Button	Can adjust the door open time through the DHB on the COP when need to hold the door opening.	○
Voice Announcement	With the function, voice announcer announces floor to be reached on each landing, and forecast subsequent running direction before each door closing.	○
IC Card System	IC card management implements right management for specific floor through car and hall card reading system, intelligent manage the passengers. The function is only effective for elevator and can' t be integrated with other IC card management system in building.	○
RLEV-Re-Leveling Operation	Stopping error between the car sill and landing sill exceeds a limit due to load changing of passenger shall be corrected by automatically re-leveling.	○
Door Opening For Dstandby At Main Landing	With the function, when elevator is not used, it will wait with door opened at main landing.	○
Visit	The function is to open elevator for visitor.(The function acts together with building system and intelligent IC system)	○
Hall Arrival Gong	Up/down arrival gong will be provided in hall on each landing to inform passenger of arriving of elevator with this optional function.	○
Auxiliary Operation Panel	Auxiliary Operation Panel can be provided in addition to main operation panel, passenger can register and door operation via auxiliary operation panel.	○
Operation Panel For Handicapped	Operation panel for handicapped can be selected for special operation by handicapped.	○
Machine Room Sound Insulation And Shock Absorber	There is sound insulation and shock absorber under the machine bearing, to reduce the noise between cabin and top floor.	○
FLP-Fan And Light Protection	Elevator will enter energy saving mode under no operation, turn off the car light and fan automatically within present time after door closing, and resume after new command is received.	○
PRK Parking	Elevator in same group will park on different floors once spare in order to shorten the response time.	○
CFT-Cafeteria Time	More open time for the cafeteria floor to meet with the requirement of the extra passenger flow.	○
MIT&MOT-Moderate Incoming &Outgoing Traffic	Aiming at relieving the traffic peak in the building, for example, morning peak or evening park, all the elevators on services at lobby will be activated once the load reached a predetermined value(generally 50%), and this model will continue at the predetermined peak times.(This function only available to triplex and group control.)	○
TFT Display	TFT Display can show the video or music ordered by customer.	○
Over Station Warning	Elevator will remind the passenger through buzzer over station, provide special service for blind passenger.	○
Time Setting	Time setting to auto control the elevator.	○

► System Safety

Function	Function	Remarks
Contact Detection And Protection On Safety Contactor	The system detects reliable action of safety relay and contact on contactor. If nonconformity of action of contact with driving state of coils found, any work in car will stopped.	●
Brake Feedback & Detection	Brake relay signal is always monitored. If nonconformity of actual state of brake relay with preset command is found, running will be stopped.	●
Independent Dual Brake	Independent actuators are used for the main engine.	●
Running Time Limiter	If leveling switch doesn't act after continuous running for time specified by running time limiter (max 45 s), any work in car will be stopped.	●
Over Speed Protection	The function is to protect elevator against safety problem caused by running at speed out of control range.	●
Low Speed Protection	The function is to protect elevator against safety problem caused by running at speed lower than control range.	●
OHT-Drive Over Heat Protection	Self-protection mode will be achieved if the temp of the motor exceeds the preset value due to the heat made by motor itself or the high temp in the environment. The car stops at the nearest floor, unload and shut down the light and ventilation device; once the temp falls down to normal, the car will recovery.	●
Safety Circuit Fault Protection	When safety circuit fault signal is received, elevator will be subject to emergency stop, and prevented from running under fault.	●
Main Control CPU WDT Protection	WDT protection is provided on main control board. When fault of CPU or program is detected, WDT circuit will forcibly disconnect main controller output point and reset CPU.	●
Grid Flter Monitoring	If the voltage fluctuate continuously in one period, system will auto alarming.	●
Speed Detection	Once the system detect the actual running speed is unconformity with the preset speed, will shut off the safety circuit automatically and alarming.	●
RIN-Re-Initialized	When the power recovered from a cut, position signals cannot be given or the position cannot be detected, the car will move to lobby and reinitiate. After that the floor info can be display and the elevator backs to normal.	●
Recover Running	Elevator recover from shut off, if it's out of the leveling zone, the system will run to the leveling position under lower speed, and auto open the door to recovery.	●

► Maintenance Function

Function	Function	Remarks
Five Parties Intercom	The function is keep contact with machine room and monitoring center via intercom system provided on COP, car top and pit. Cable from machine room to monitoring center shall be solved by client.	●
Floor Height Self-Learning	Elevator automatically learns the floor height.	●
Self-Position Of Max. Torque	After each power failure recovery, elevator re-establishes the absolute position of max. Torque point to ensure running in high efficiency state.	●

Pit Ladder	Ladder is provided in pit for maintainer.	●
Fault Recording/Reference	The latest 20 faults can be recorded, including the fault time, floor and code.	●
TCI-Top Of Car Inspection	Inspection box is provided on the top of car, safer and easier for maintain.	●
Inspection In Machine Room	Inspection running can be carried out in machine room.	●
Leveling Adjustment	If there's slightly deflection in elevator leveling, manual intervention can be implemented with the function.	●
Test Running	The function is designed for testing or examining new elevator. Elevator can automatically run after some parameters of AIO is established as state of test running. Total times of automatic running and interval between runs can both be established by parameter setting.	●
Full Shaft Double Control Lighting	Double control lighting is provided by installing lamps through shaft wall.	●

► Extension Function

Function	Function	Remarks
Special Letter Display	Character shown on each floor can be set via manipulator. For example, shown B for Base floor.	○
Group Control	Used for two or more elevators, response with the optimize solution, avoid the repeat stopping, save the waiting time of passenger, increase the efficiency.	○
BA-Building Monitor Ports	Elevator with BA function can provide scattered elevator status for computer management of the building, such as running directions, floor numbers, safety signals, door signals.	○
REM	24 hours remote elevator monitoring can be implemented through internet or telephone line. Auto alarming to REM center when elevator faulty.	○
AMS-Area Monitoring Screen	It can be installed in the porter's lodge, simply display the condition signals by LED indicators and lock/unlock the elevator.	○
Air Conditioner	Adjust the air in cabin, including temperature, humidity and cleanliness, to make a comfortable environment.	○
UV Sterilization	UV Sterilization system clean the air into the cabin.	○
Negative Oxygen Ions Bactericidal	Add the negative oxygen ions generator to the ventilation system, sterilization and purification of the air in cabin.	○

For more functions please consult the sales representatives.

LAYOUT DRAWING

UN-Victor (R)

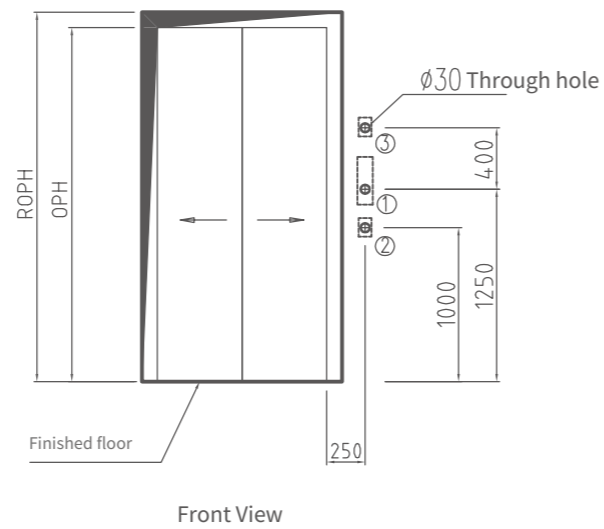
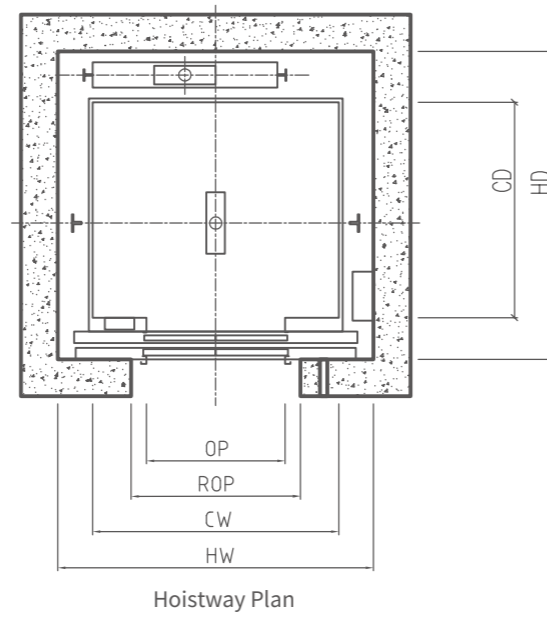
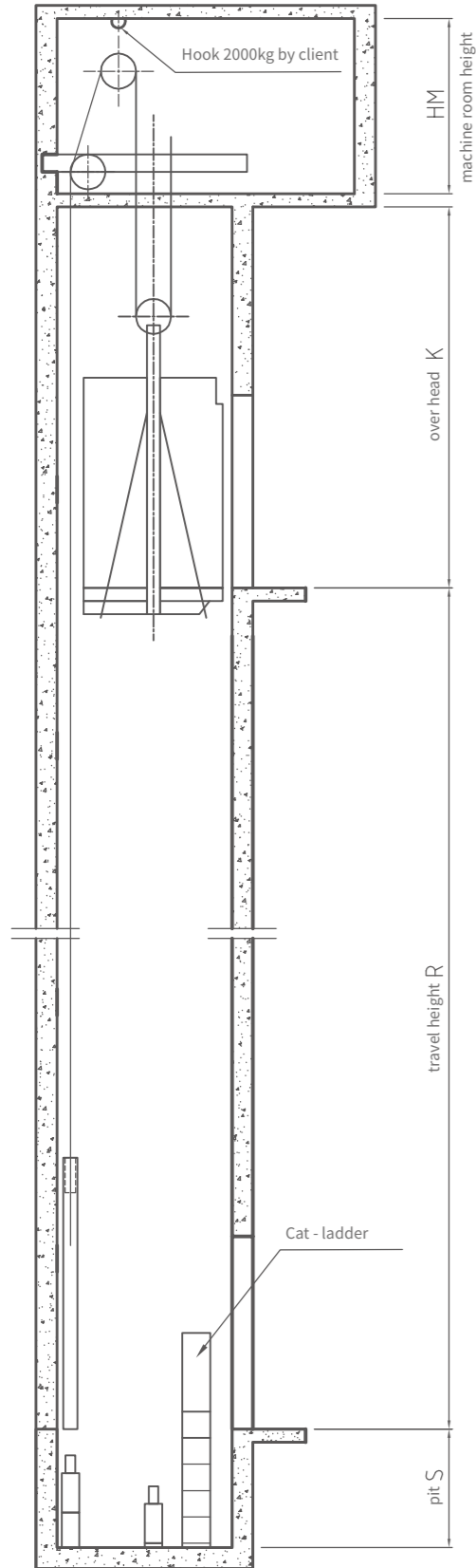

- 1.Button and display;
- 2.Lock switch (if with EFO) only on base floor;
- 3.Fire switch (if with EFO) only on base floor.

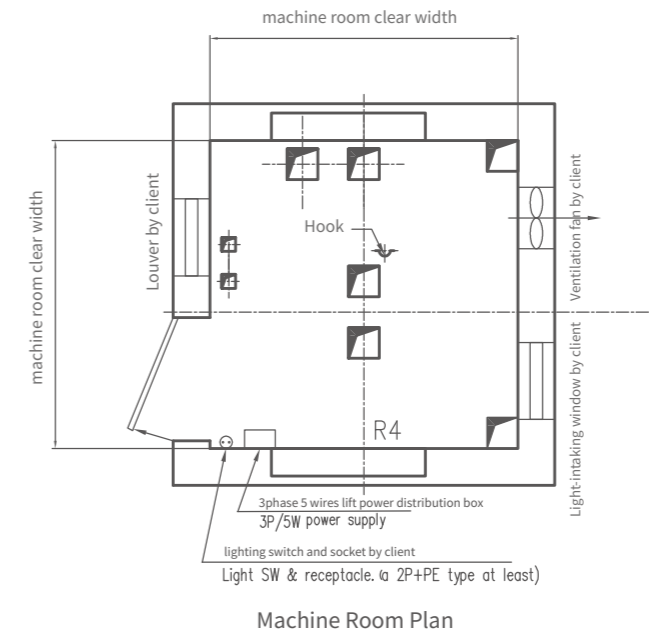

Capacity (kg)	Speed (m/s)	Cabin inner size CW(mm)×CD(mm)	Opening size OP(mm)×OPH(mm)	Shaft inner size HW(mm)×HD(mm)	Min. pit depth S(mm)	Min. overhead K(mm)
630	1.0	1250X1300	800X2100 (2P-CO)	1750X1950	1350	3950
	1.5				1450	4050
	1.75				1450	4100
680	1.0	1400X1100	800X2100 (2P-CO)	1850X1750	1350	3950
	1.5				1450	4050
	1.75				1450	4100
800	1.0	1400X1350	800X2100 (2P-CO)	1850X1950	1350	3950
	1.5				1450	4050
	1.75				1450	4100
	2.0			1950X2100	1800	4800
	2.5				2050	5000
1000	1.0	1600X1400	900X2100 (2P-CO)	2050X2000	1350	3950
	1.5				1450	4050
	1.75				1450	4100
	2.0			2150X2100	1800	4800
	2.5				2050	5000
1050	1.0	1600X1500	900X2100 (2P-CO)	2050X2100	1350	3950
	1.5				1450	4050
	1.75				1450	4100
	2.0			2150X2200	1800	4800
	2.5				2050	5000
1150	1.0	2000X1350	1100X2100 (2P-CO)	2550X2100	1500	4450
	1.5				1600	4550
	1.75				1700	4700
	2.0				1800	4800
	2.5				2050	5000
1350	1.0	2000X1550	1100X2100 (2P-CO)	2550X2300	1500	4450
	1.5				1600	4550
	1.75				1700	4700
	2.0				1800	4800
	2.5				2050	5000
1600	1.0	2000X1750	1100X2100 (2P-CO)	2550X2500	1500	4450
	1.5				1600	4550
	1.75				1700	4700
	2.0				1800	4800
	2.5				2050	5000

· The pit depth and overhead is calculated under 1.75m/s and buffer distance 150mm.
 · Above drawing is for reference only.

LAYOUT DRAWING

UN-Victor (R) Stretcher elevator

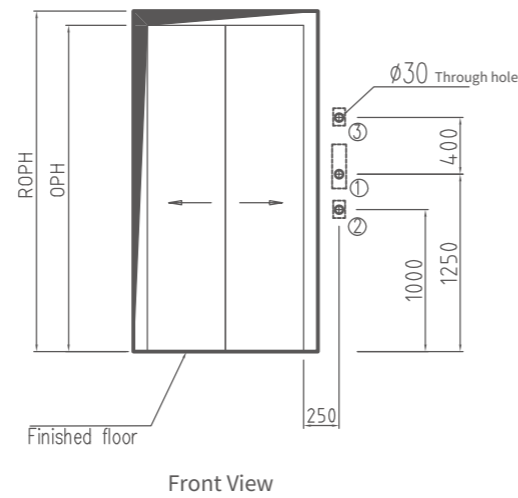
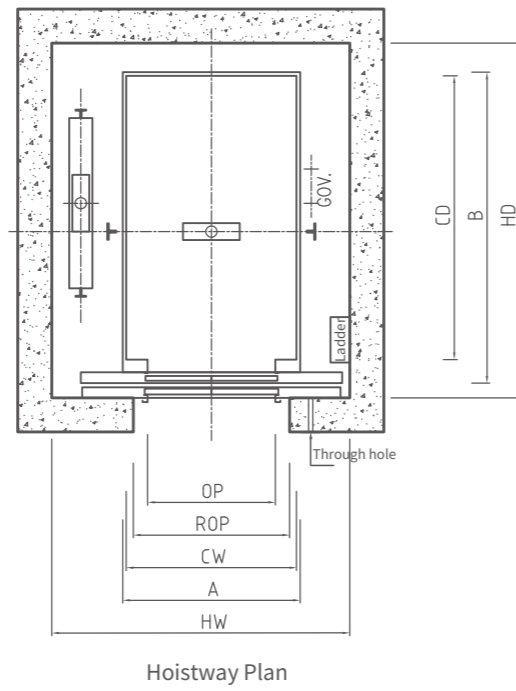
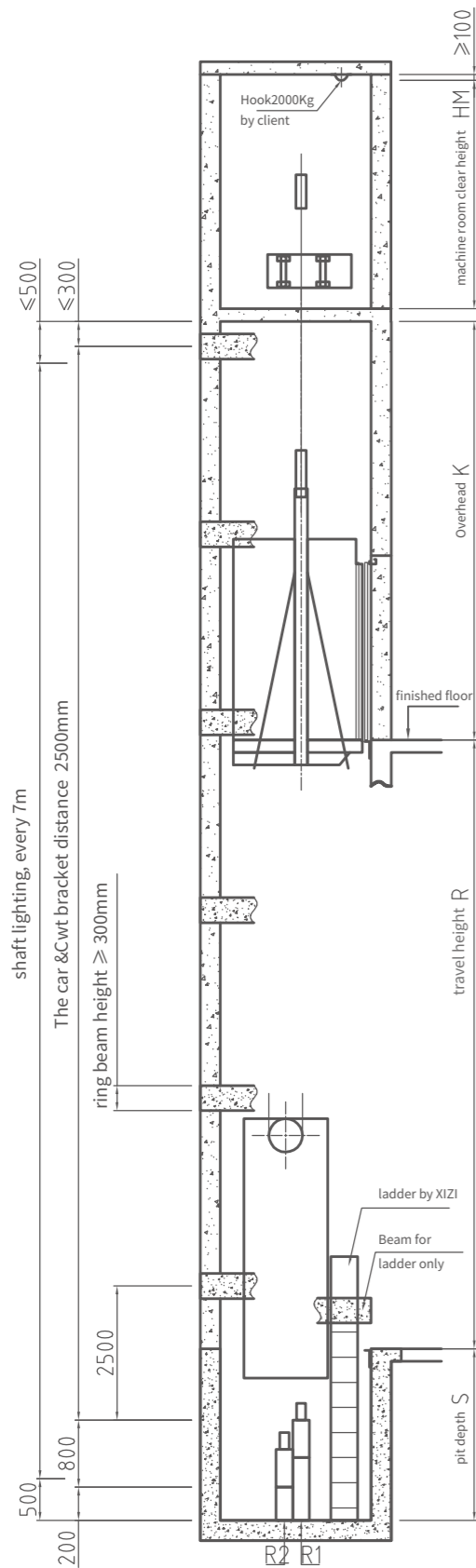

- 1.Button and display;
- 2.Lock switch (if with EFO) only on base floor;
- 3.Fire switch (if with EFO) only on base floor.

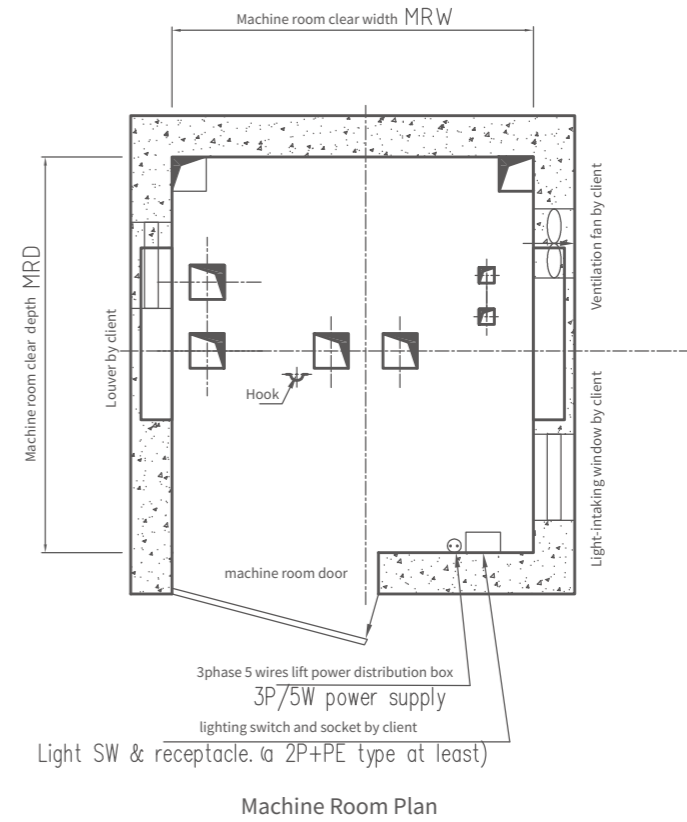

Capacity (kg)	Speed (m/s)	Cabin inner size CW(mm)×CD(mm)	Opening size OP(mm)×OPH(mm)	Shaft inner size HW(mm)×HD(mm)	Min. pit depth S(mm)	Min. overhead K(mm)
1000	1.0	1200X2000	900X2100 (2P-CO)	2000X2400	1350	3950
	1.5				1450	4050
	1.75				1450	4100
	2.0				2050	5000
	2.5				2100	5050

- Above drawing is for reference only.
- The pit depth and overhead is calculated based on 1.75m/s and buffer distance 150mm.
- Above drawing is for reference only.

LAYOUT DRAWING

UN-Victor (T) 1.75~3.0m/s

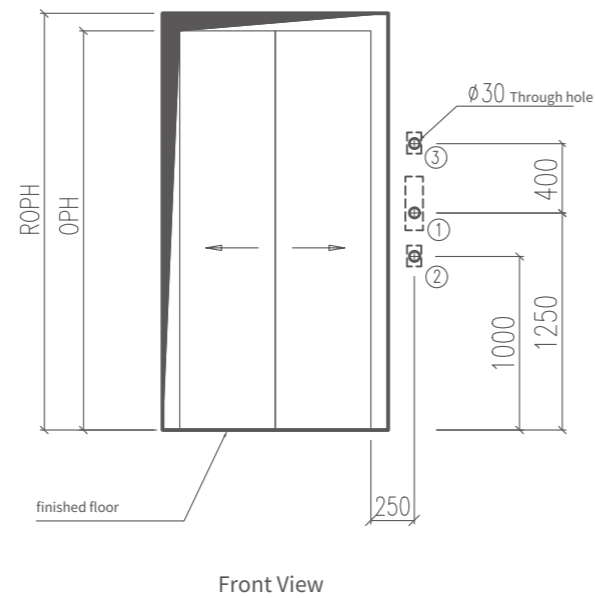
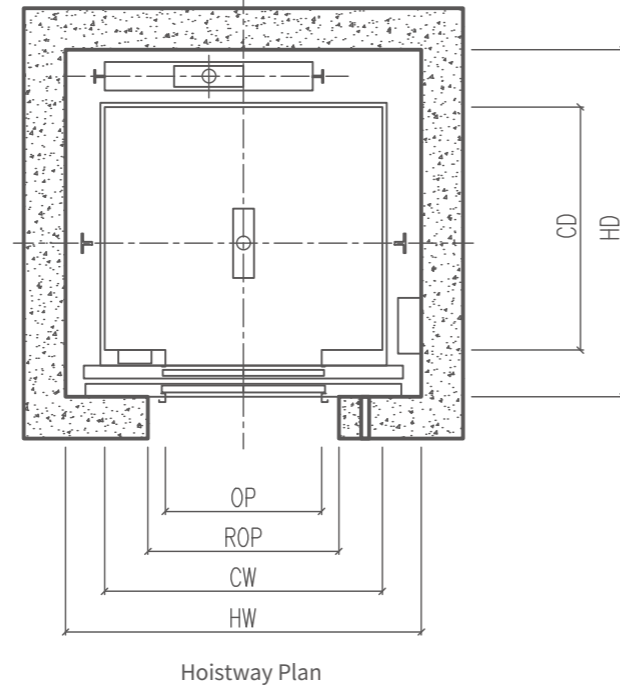
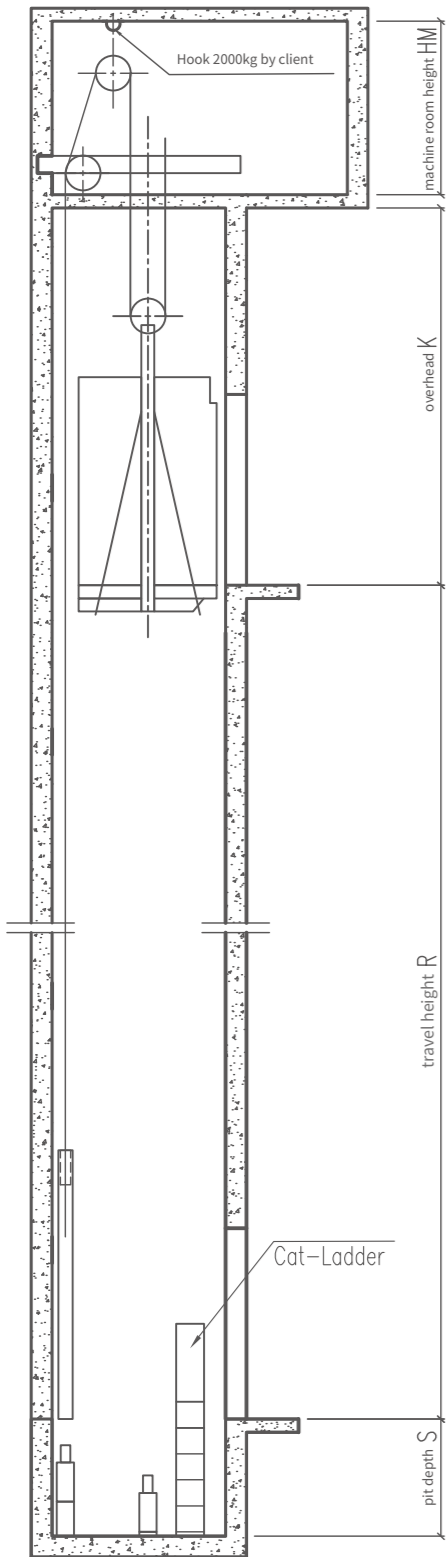

- 1.Button and display;
- 2.Lock switch (if with EFO) only on base floor;
- 3.Fire switch (if with EFO) only on base floor.

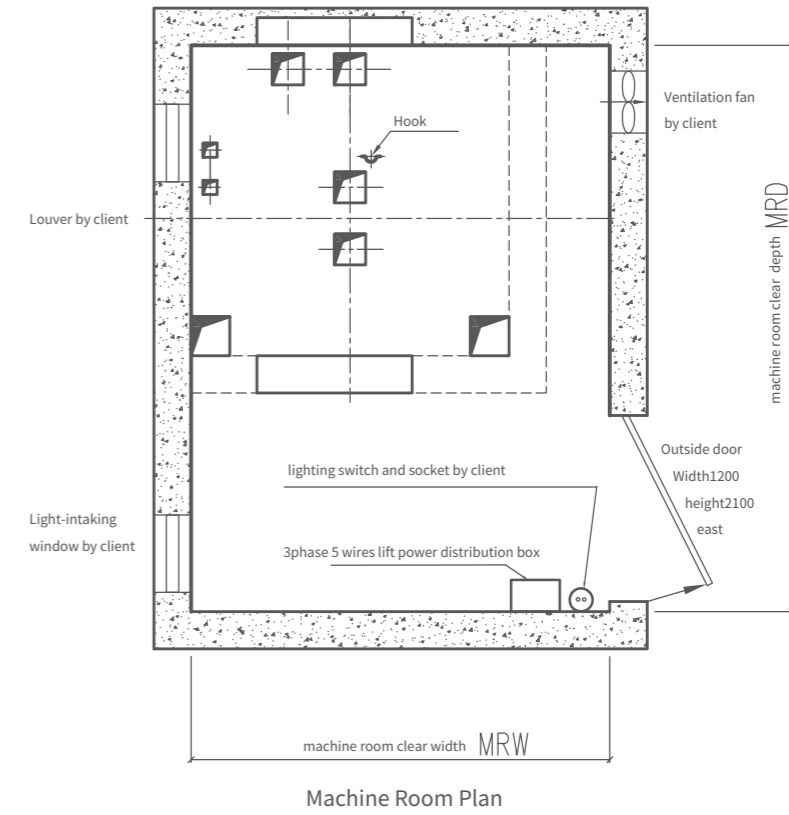

Capacity (kg)	Speed (m/s)	Cabin inner size CW(mm) × CD(mm)	Opening size OP(mm) × OPH(mm)	Shaft inner size HW(mm) × HD(mm)	Min. pit depth S(mm)	Min. overhead K(mm)	Optional travel reducing device
1000	1.75	1600X1400	900X2100 (2P-CO)	2050X2000	1450	4450	\
	2			2150X2100	1800	5000	
	2.5	1600X1500		2050	5200	Y	
	3			2150X2200	2350		5350
1050	3	1600X1500	900X2100 (2P-CO)	2650	5650	N	
	1.75			2050X2100	1450	4450	\
	2				1800	5000	
	2.5			2150X2200	2050	5200	Y
3	2350	5350					
1150	3	2000X1350	1100X2100 (2P-CO)	2650	5650	N	
	1.75			2550X2100	1700	4900	\
	2				1800	5000	
	2.5			2600X2100	2050	5200	Y
3	2350	5350					
1350	3	2000X1550	1100X2100 (2P-CO)	2650	5650	N	
	1.75			2550X2300	1700	4900	\
	2				1800	5000	
	2.5			2600X2300	2050	5200	Y
3	2350	5350					
1600	3	2000X1750	1100X2100 (2P-CO)	2650	5650	N	
	1.75			2550X2500	1700	4900	\
	2				1800	5000	
	2.5			2600X2500	2050	5200	Y
3	2350	5350					

• Note: For 3m/s the cabin inner is 2500mm (ceiling height 200mm)

LAYOUT DRAWING

UN-Victor (T)3.5~4.0m/s

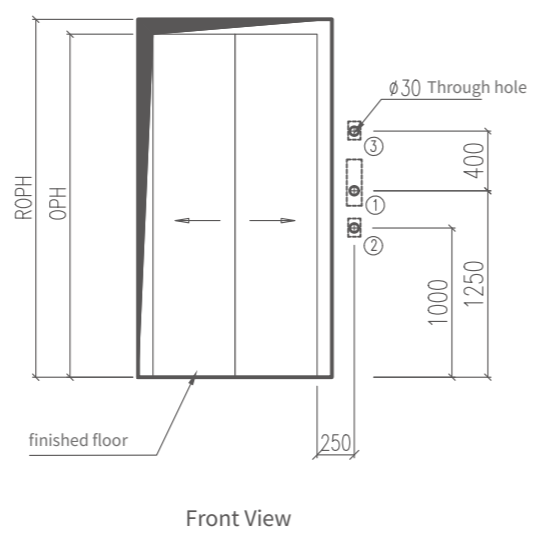
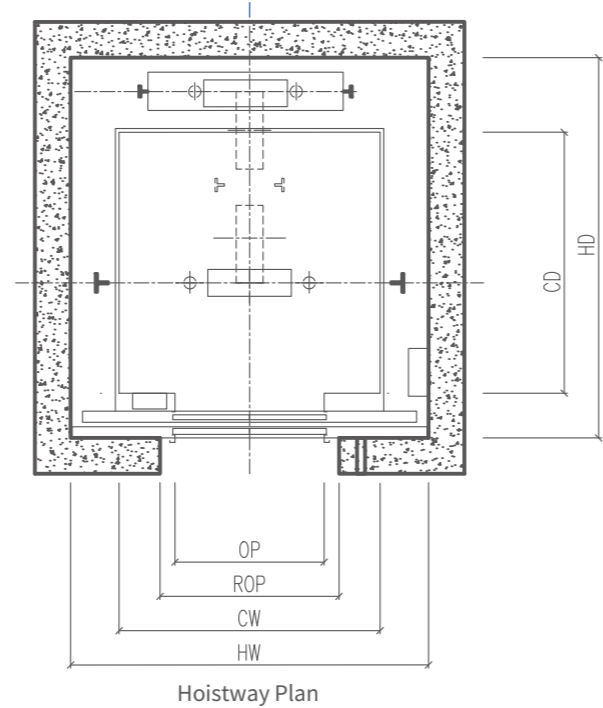
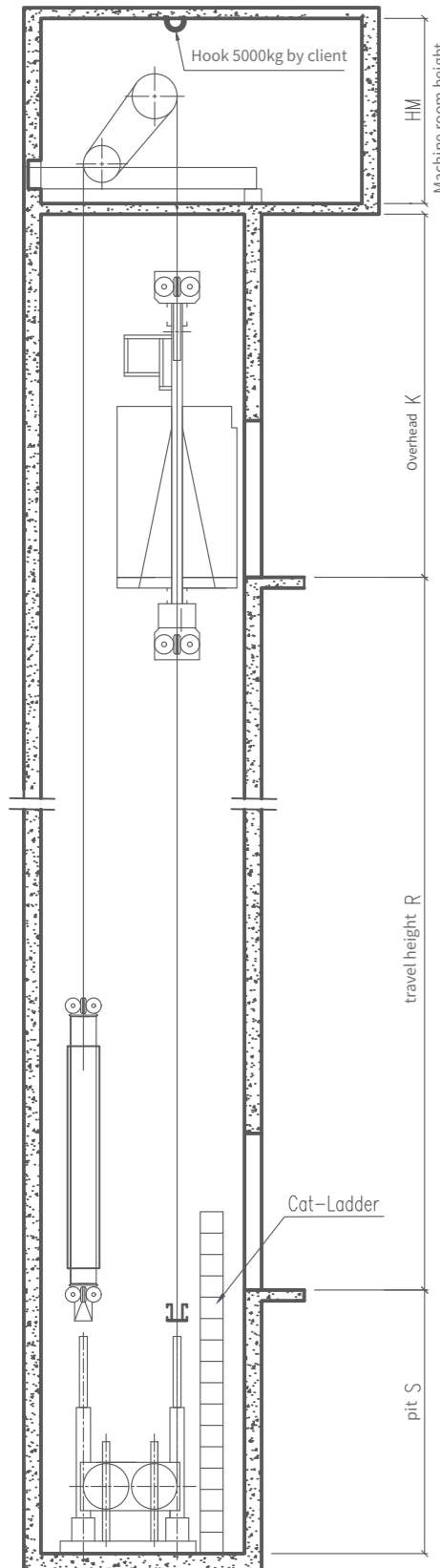

- 1.Button and display;
- 2.Lock switch (if with EFO) only on base floor;
- 3.Fire switch (if with EFO) only on base floor.

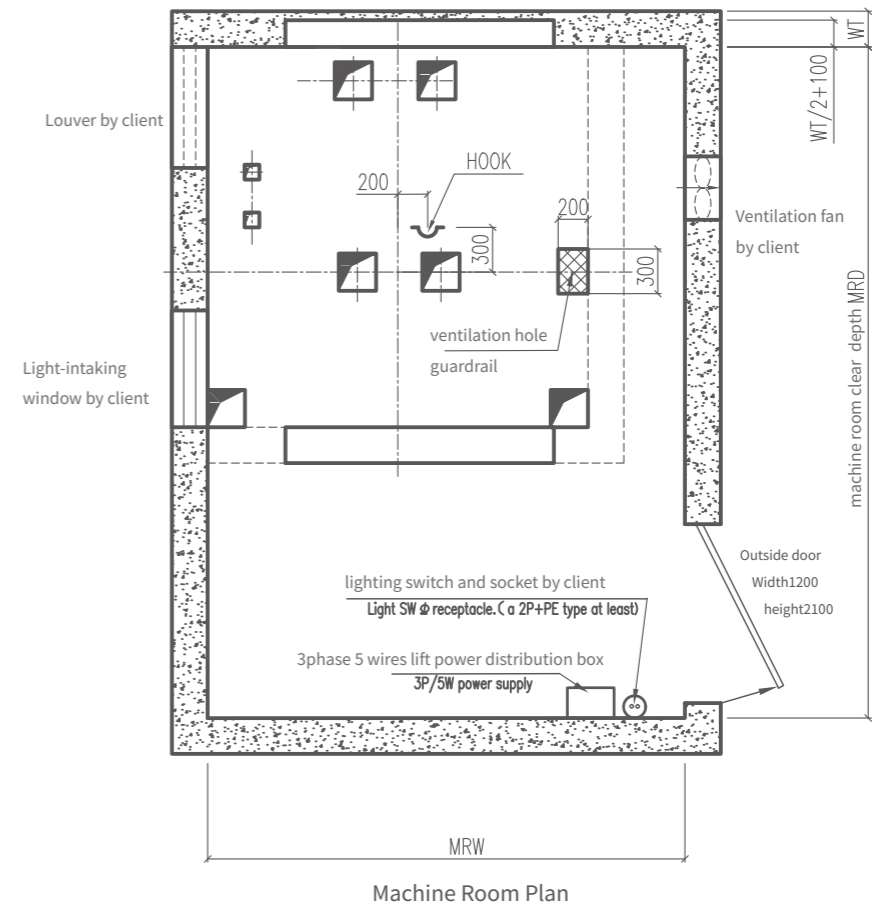

Capacity (kg)	Speed (m/s)	Cabin inner size CW(mm)×CD(mm)	Opening size OP(mm)×OPH(mm)	Shaft inner size HW(mm)×HD(mm)	Min. pit depth S(mm)	Min. overhead K(mm)	Optional travel reducing device
1000	3.5	1600X1500	900X2300(2P-CO)	2150X2300	3750	6300	N
	4	1600X1500	900X2300(2P-CO)	2150X2300	4000	6650	
1350	3.5	1750X1750	1000X2300(2P-CO)	2400X2550	3750	6300	
	4	1750X1750	1000X2300(2P-CO)	2400X2550	4000	6650	
1600	3.5	2000X1750	1100X2300(2P-CO)	2550X2550	3750	6300	
	4	2000X1750	1100X2300(2P-CO)	2550X2550	4000	6650	
1000	3.5	1600X1500	900X2300(2P-CO)	2150X2300	3400	5600	Y
	4	1600X1500	900X2300(2P-CO)	2150X2300	3560	5900	
1350	3.5	1750X1750	1000X2300(2P-CO)	2400X2550	3400	5600	
	4	1750X1750	1000X2300(2P-CO)	2400X2550	3560	5900	
1600	3.5	2000X1750	1100X2300(2P-CO)	2550X2550	3400	5600	
	4	2000X1750	1100X2300(2P-CO)	2550X2550	3560	5900	

Note: for 3.5~4m/s cabin inner height is 2700mm(ceiling height 200mm)

LAYOUT DRAWING

UN-Victor MRL 630~1050kg

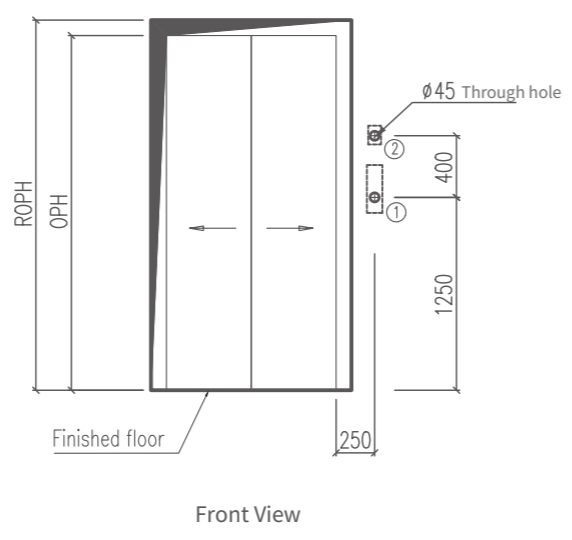
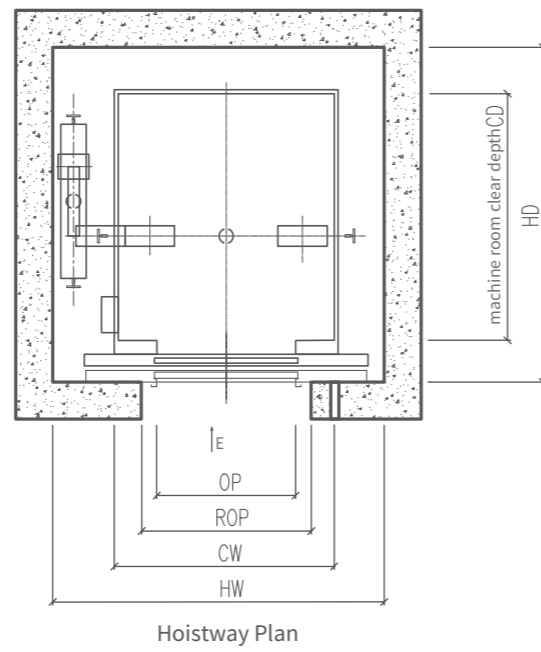
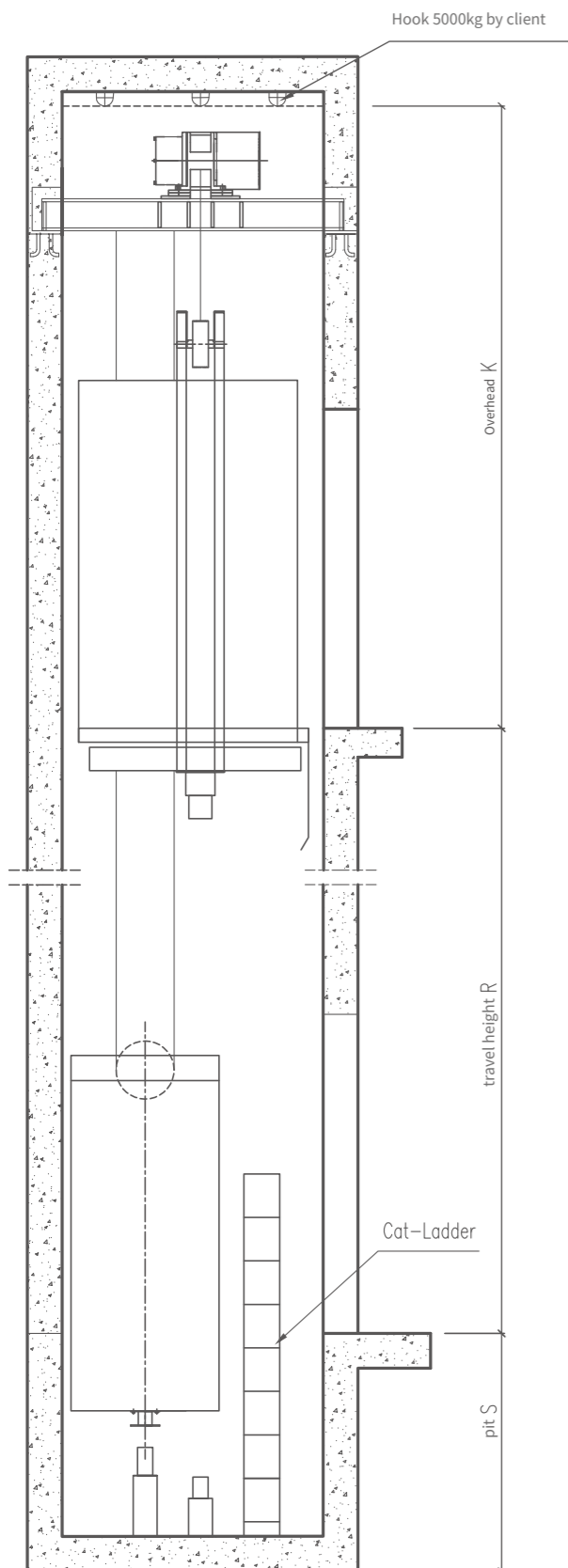

- 1.Button and display;
- 2.Fire switch (if with EFO) only on base floor.

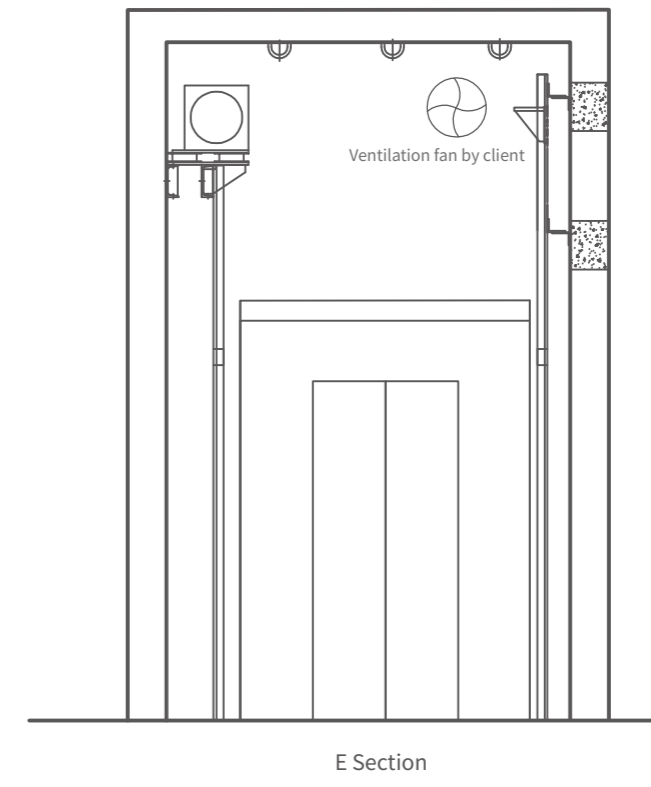

Capacity (kg)	Speed (m/s)	Cabin inner size CW(mm)×CD(mm)	Opening size OP(mm)×OPH(mm)	Shaft inner size HW(mm)×HD(mm)	Min. pit depth S(mm)	Min. overhead K(mm)
630	1.0	1050X1400	700X2100 (2P-CO)	1800X1800	1400	4150
	1.5				1450	4500
	1.75					
800	1.0	1350X1400	800X2100 (2P-CO)	2000X1800	1400	4150
	1.5				1450	4500
	1.75					
1000	1.0	1600X1400	900X2100 (2P-CO)	2250X1800	1400	4150
	1.5				1450	4500
	1.75					
1050	1.0	1600X1500	900X2100 (2P-CO)	2250X1900	1400	4150
	1.5				1450	4500
	1.75					

* Please contact sales for details.
 · The pit depth and overhead is calculated based on buffer distance 150mm.
 · Above drawing is for reference only.

LAYOUT DRAWING

UN-Victor MRL 1150~1600kg

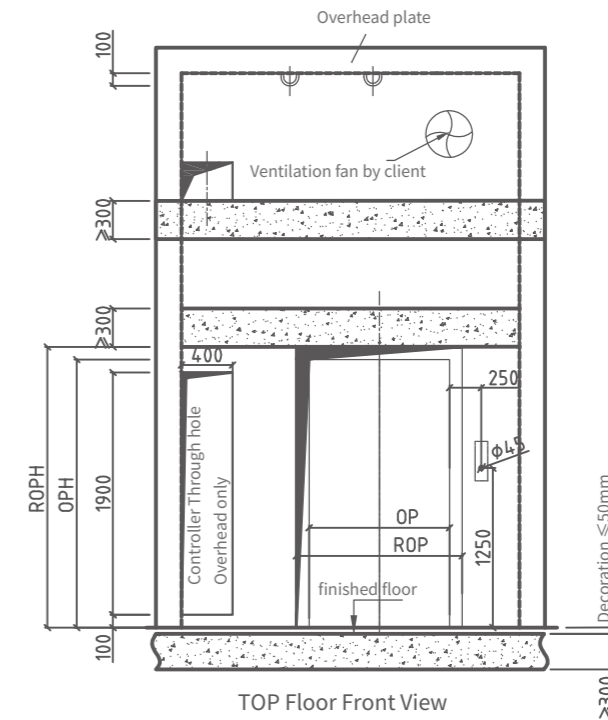
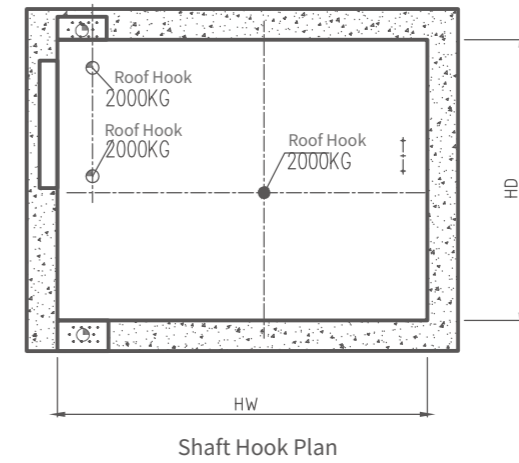
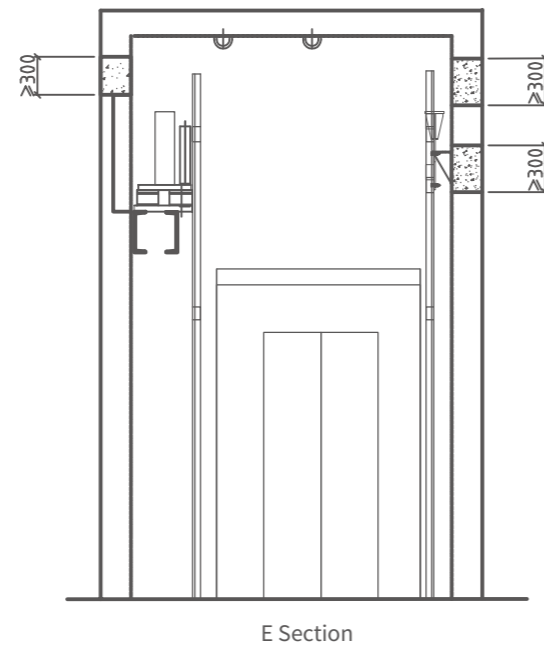
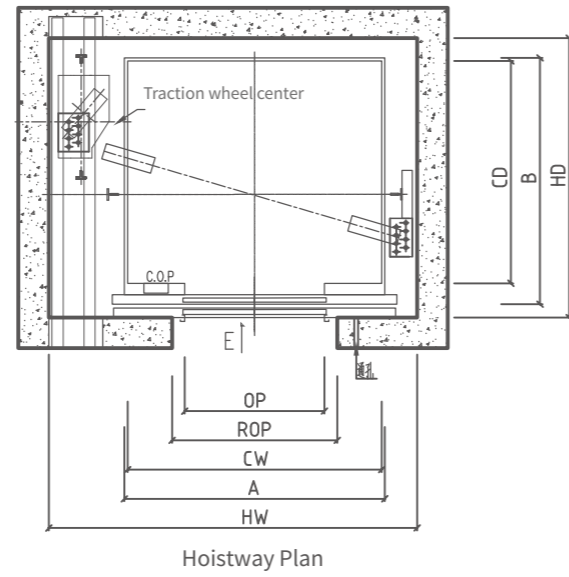
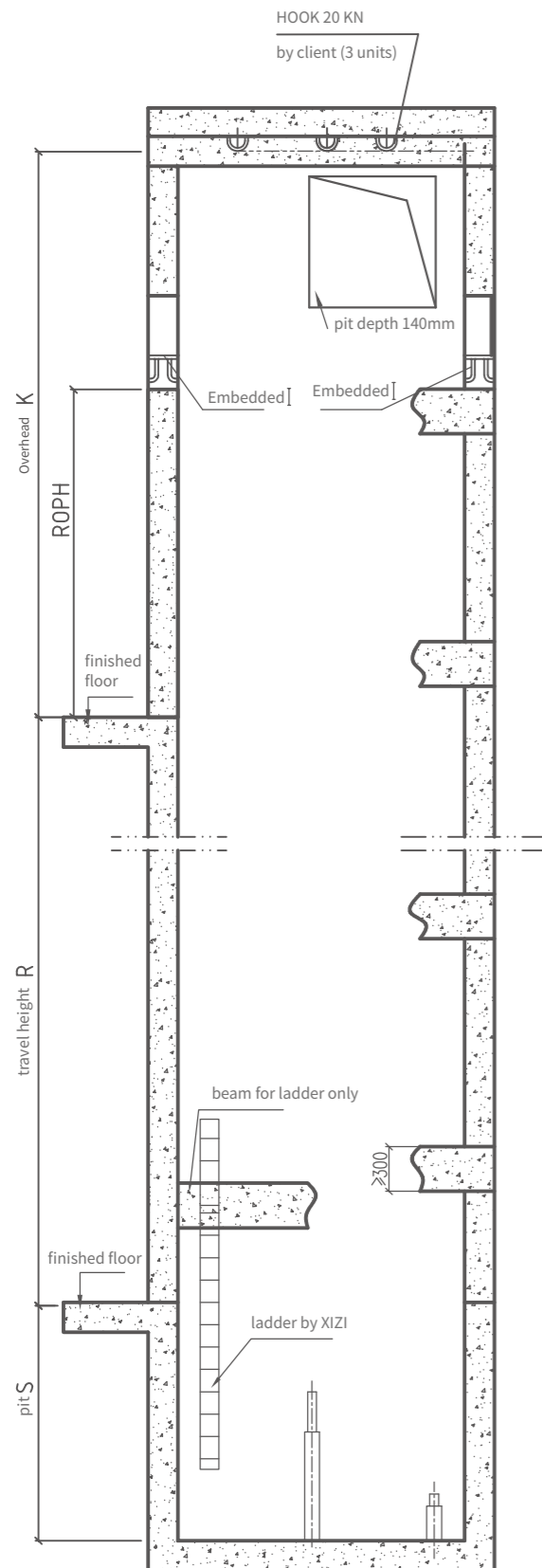

Capacity (kg)	Speed (m/s)	Cabin inner size CW(mm)×CD(mm)	Opening size OP(mm)×OPH(mm)	Shaft inner size HW(mm)×HD(mm)	Min. pit depth S(mm)	Min. overhead K(mm)
1150	1.0	1700X1550	1000X2100 (2P-CO)	2600X2150	1600	4200
	1.5				1700	4300
	1.75					
1350	1.0	1800X1650	1100X2100 (2P-CO)	2700X2150	1600	4200
	1.5				1700	4300
	1.75					
1600	1.0	2000X1750	1100X2100 (2P-CO)	2900X2150	1600	4200
	1.5				1700	4300
	1.75					

· The pit depth and overhead is calculated based on buffer distance 150mm.
 · Above drawing is for reference only.

LAYOUT DRAWING

UN-Victor MRL (T)

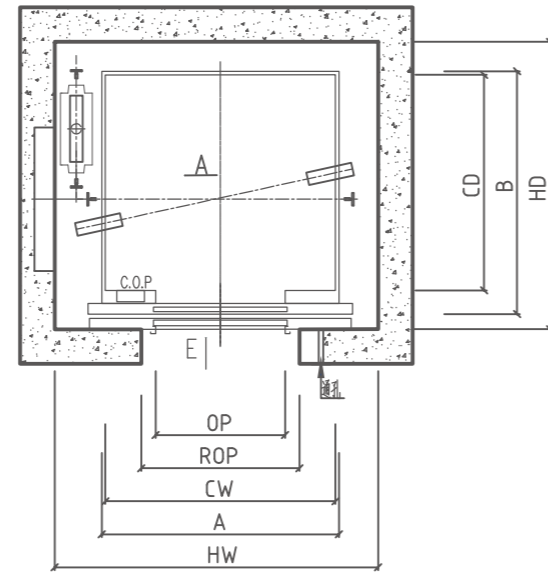
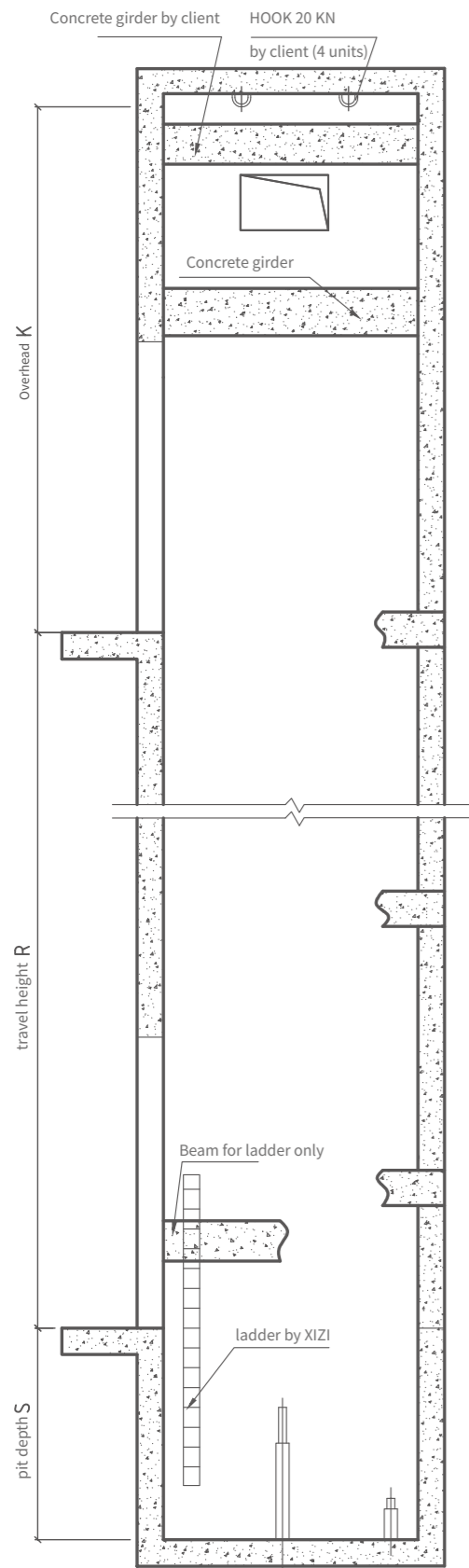

Hoistway Plan

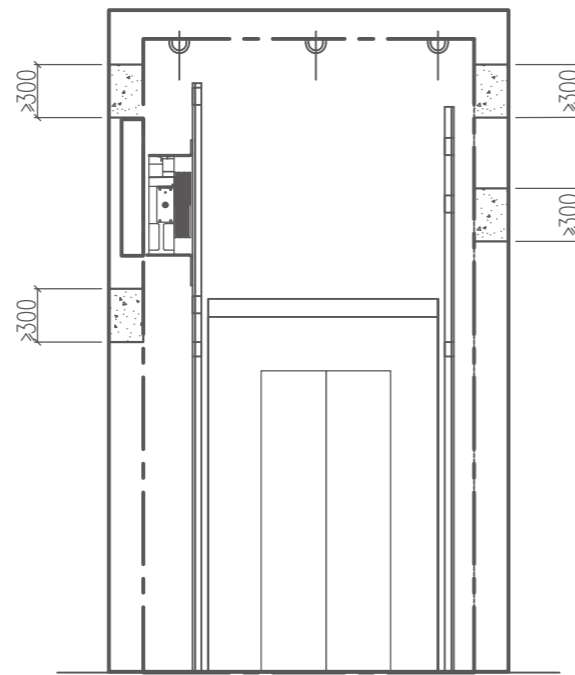

E Section

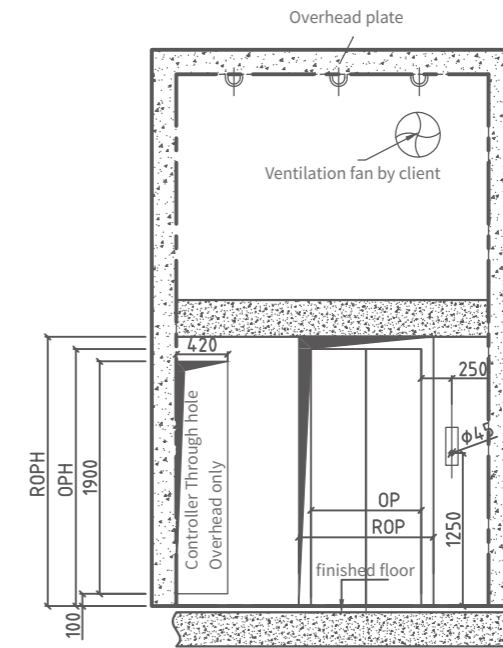

TOP Floor Front View

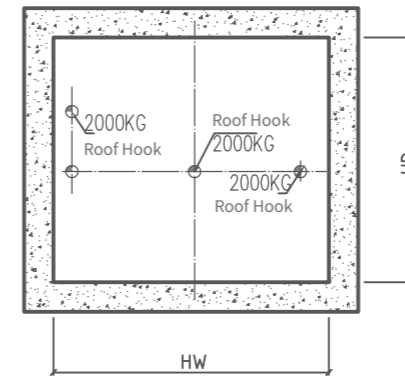

Shaft Hook Plan

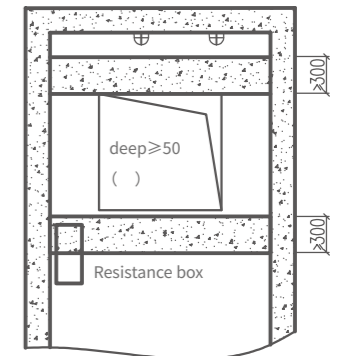

Note: please put the control cabinet according to the actual situation on site

Capacity (kg)	Speed (m/s)	Cabin inner size CW(mm)×CD(mm)	Opening size OP(mm)×OPH(mm)	Shaft inner size HW(mm)×HD(mm)	Min. pit depth S(mm)	Min. overhead K(mm)
800	1.0	1350X1400	800X2100 (2P-CO)	1900X1850	1450	3950
	1.5				1600	4200
	1.75					
1000	1.0	1600X1400	900X2100 (2P-CO)	2150X1850	1450	3950
	1.5				1600	4200
	1.75					
1050	1.0	1600X1500	900X2100 (2P-CO)	2150X1950	1450	3950
	1.5				1600	4200
	1.75					

· The pit depth and overhead is calculated based on buffer distance 150mm.
 · Above drawing is for reference only.

LAYOUT DRAWING

G3

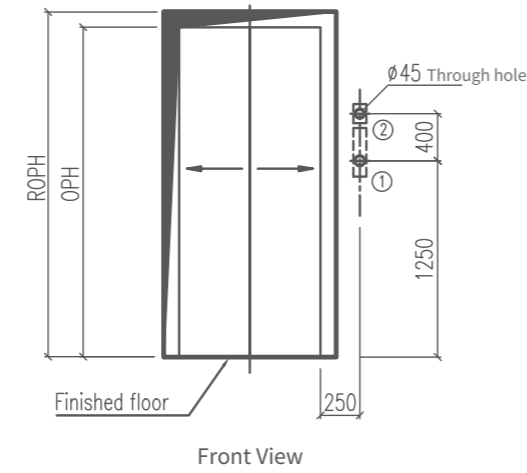
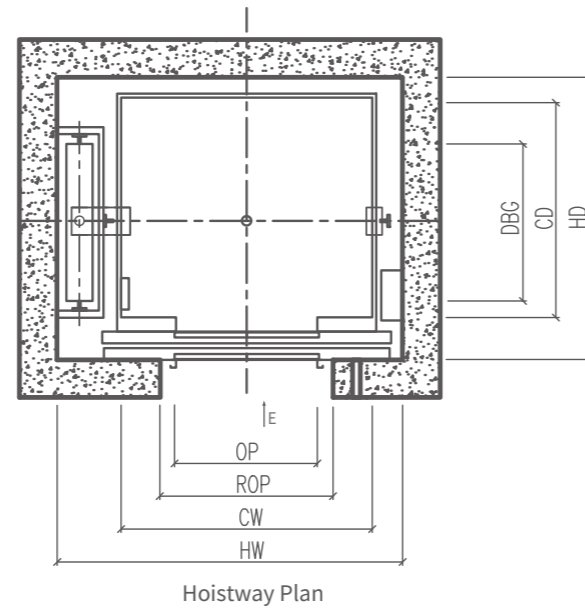
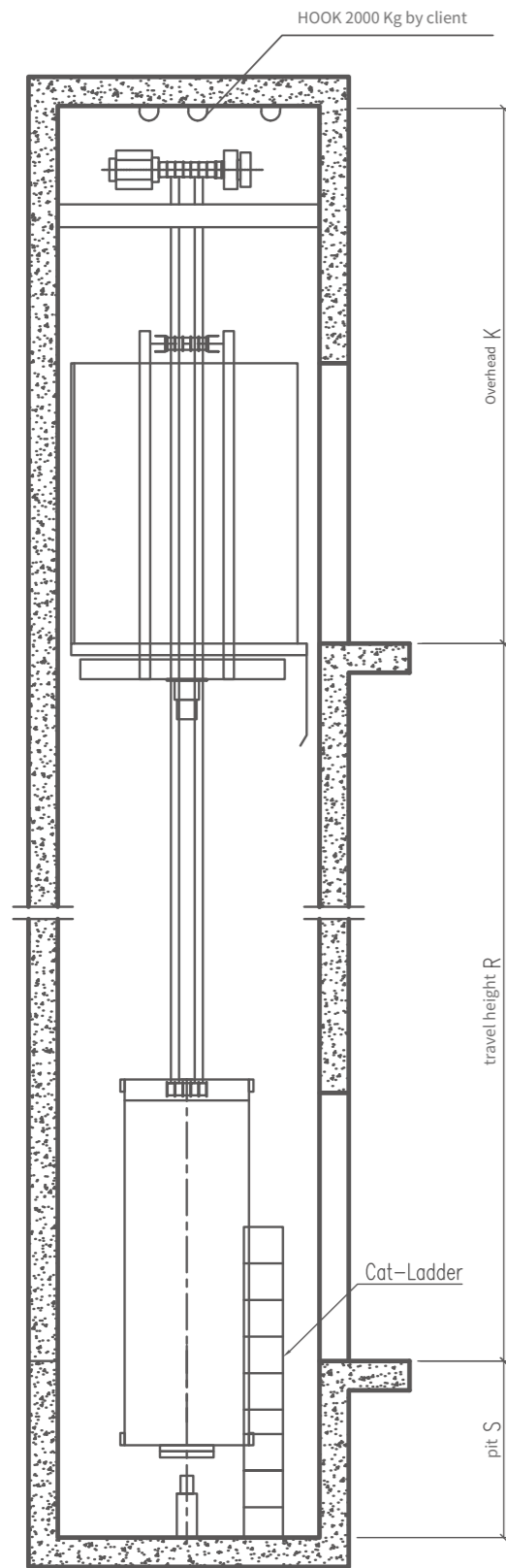

- 1.Button and display;
- 2.Fire switch (if with EFO) only on base floor.

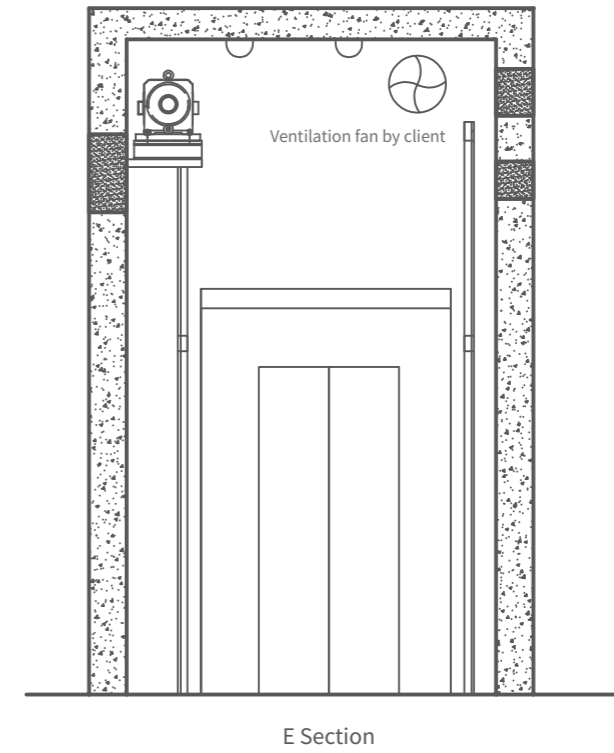

Capacity (kg)	Speed (m/s)	Cabin inner size CW(mm) × CD(mm)	Opening size OP(mm) × OPH(mm)	Shaft inner size HW(mm) × HD(mm)	Min. pit depth S(mm)	Min. overhead K(mm)
400	1.0	1000X1100	750X2100(2P-CO)	1600X1500	1200	3900
		1100X850	800X2100(2P-CO)	1800X1250	1300	3900
450	1.0	1000X1250	750X2100(2P-CO)	1600X1650	1200	3900
550	1.0	1000X1400	750X2100(2P-CO)	1600X1800	1200	3900
630	1.0	1150X1400	800X2100(2P-CO)	1750X1800	1200	3900
					1350	3900
800	1.5	1350X1400	800X2100(2P-CO)	1950X1800	1380	3970
					1400	4000
					1400	4000
1000	1.75	1600X1400	900X2100(2P-CO)	2200X1800	1350	3900
					1380	3970
					1400	4000
1050	1.0	1600X1500	900X2100(2P-CO)	2200X1900	1350	3900
					1380	3970
					1400	4000
1150	1.5	1900X1400	1000X2100(2P-CO)	2600X1800	1400	4000
					1440	4120
					1470	4180
1350	1.0	2000X1550	1100X2100(2P-CO)	2700X1950	1400	4000
					1440	4120
					1470	4180
1600	1.5	2000X1750	1200X2100(2P-CO)	2700X2150	1400	4000
					1440	4120
					1470	4180

LAYOUT DRAWING

UN-Grace (MR)

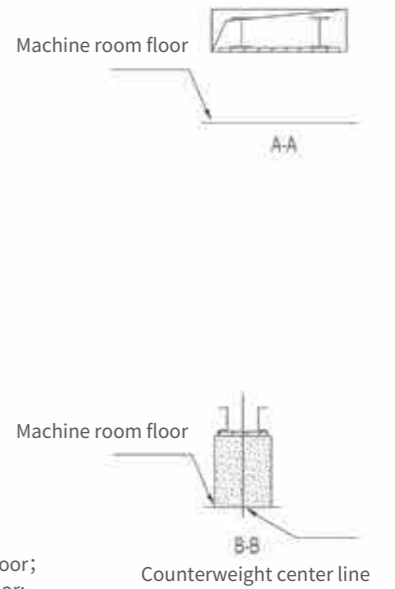
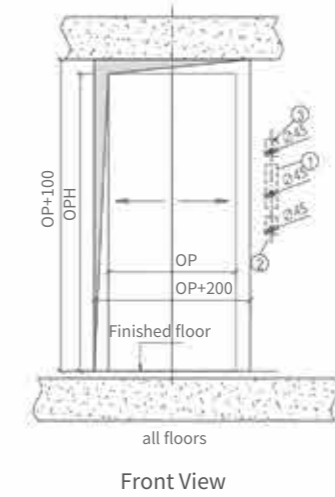
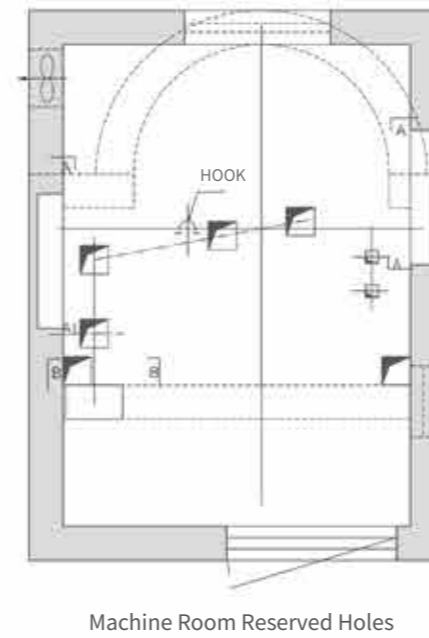
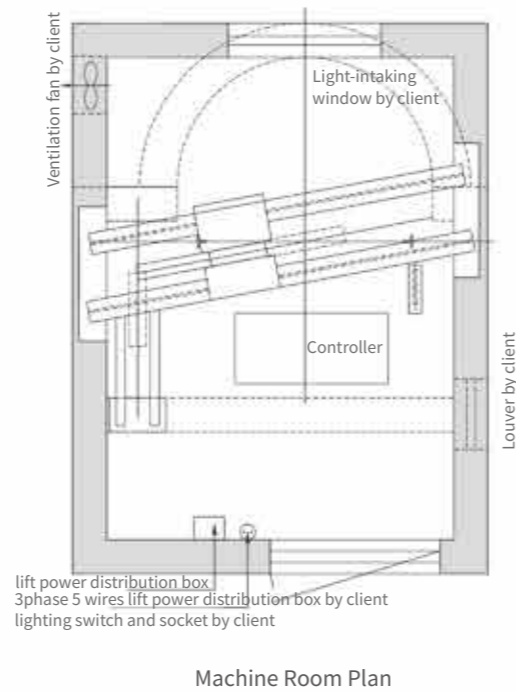
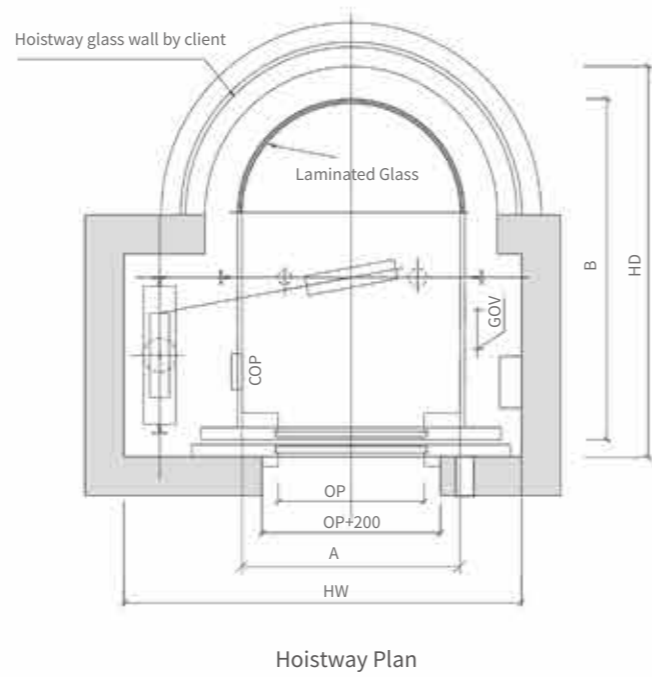
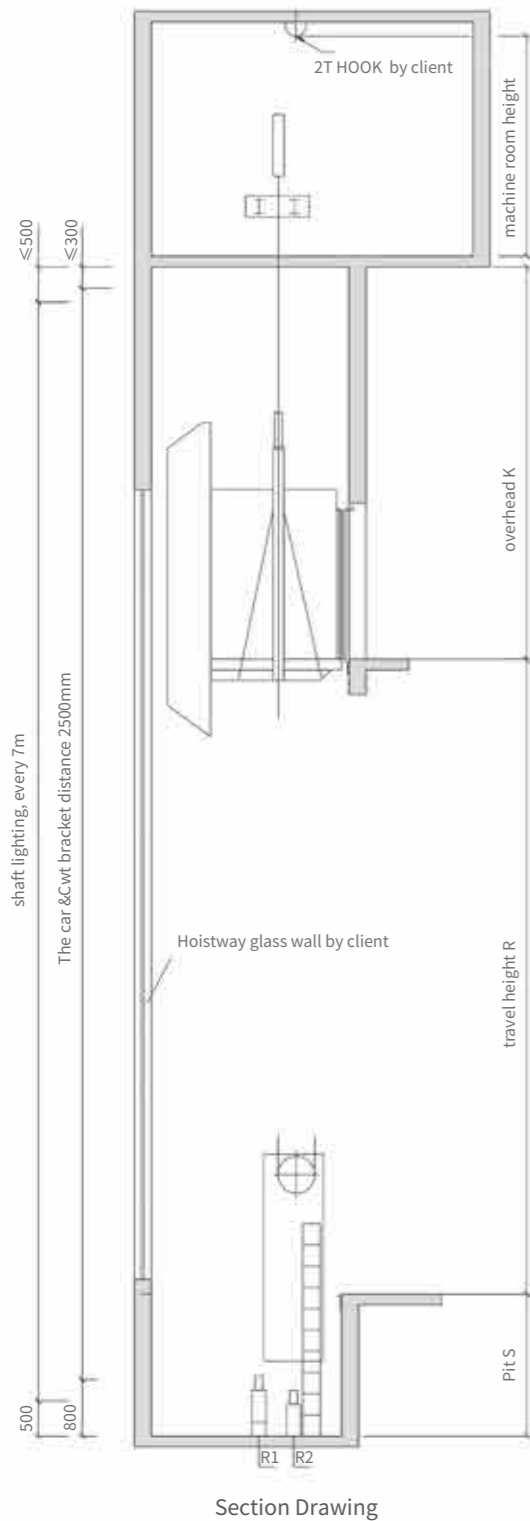

- 1.Button and display;
 - 2.Lock switch (if with EFO) only on base floor;
 - 3.Fire switch (if with EFO) only on base floor;
- Suggest to use 45mm PVC tube for wire reservation

Capacity (kg)	Speed (m/s)	Cabin outer size A(mm)×B(mm)	Opening size OP(mm)×OPH(mm)	Shaft inner size HW(mm)×HD(mm)	Min. pit depth S(mm)	Min. overhead K(mm)
800	1.0	1250X2000	800X2100 (2P-CO)	2300X2305	2100	4650
	1.5				2250	4800
	1.75				2250	4850
1000	1.0	1400X2100	900X2100 (2P-CO)	2450X2405	2100	4650
	1.5				2250	4800
	1.75				2250	4850
1150	1.0	1500X2150	1000X2100 (2P-CO)	2650X2455	2100	4650
	1.5				2250	4800
	1.75				2250	4850
1350	1.0	1600X2250	1100X2100 (2P-CO)	2750X2550	2100	4650
	1.5				2250	4800
	1.75				2250	4850
1600	1.0	1800X2350	1100X2100 (2P-CO)	2850X2655	2100	4650
	1.5				2250	4800
	1.75				2250	4850

The above figures are for reference only

LAYOUT DRAWING

UN - Victor mrl (G)

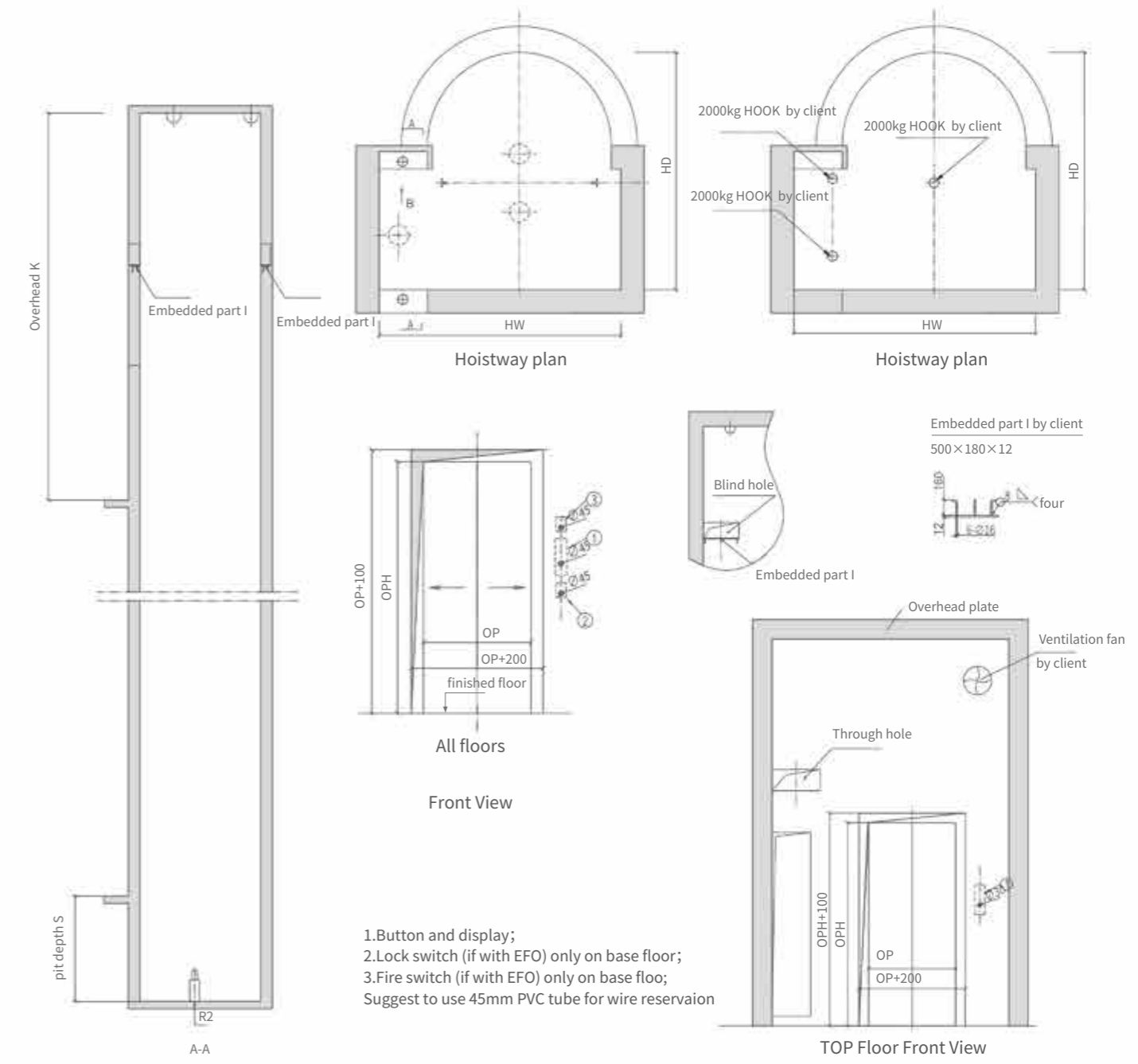
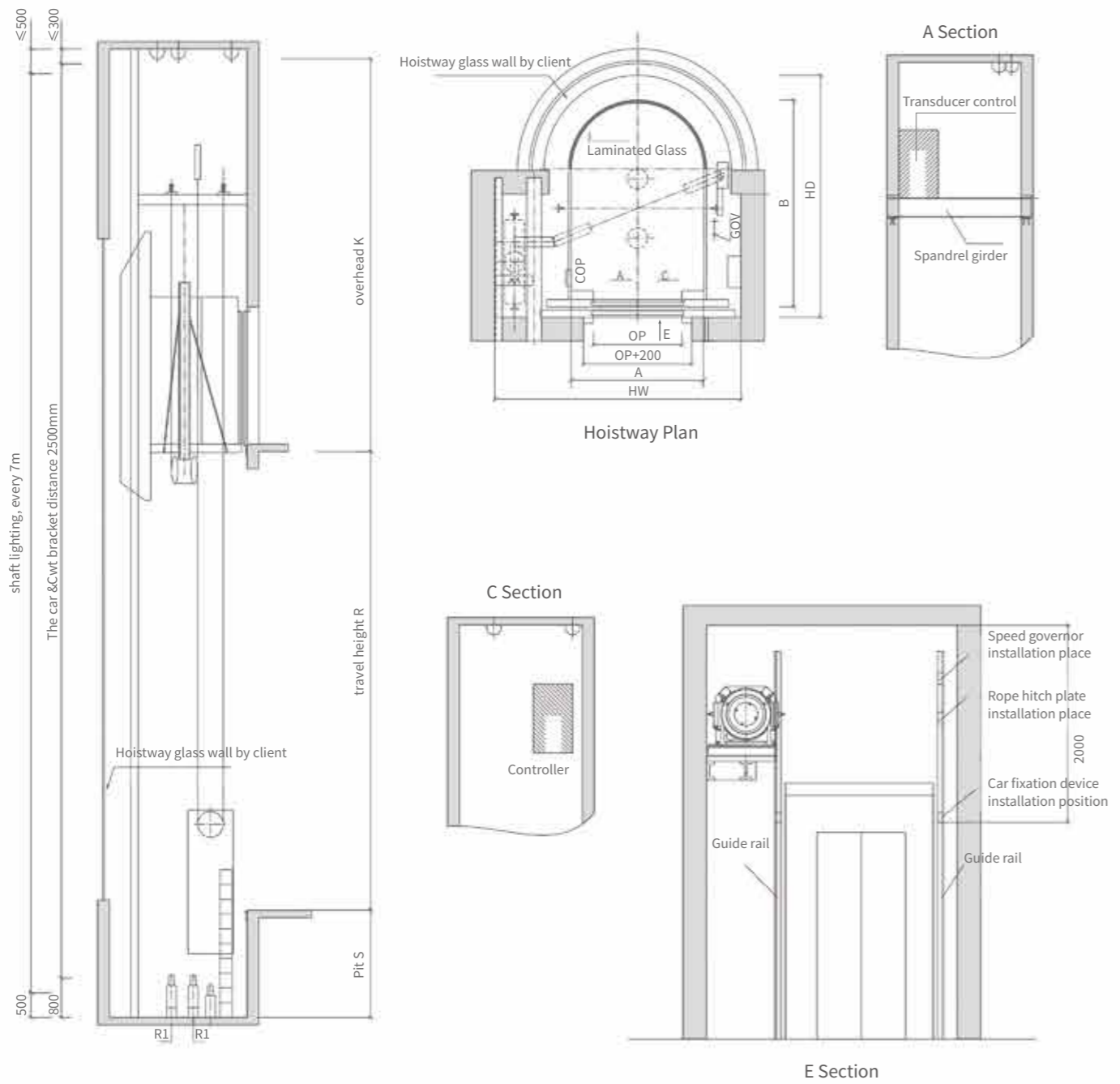

- 1.Button and display;
 - 2.Lock switch (if with EFO) only on base floor;
 - 3.Fire switch (if with EFO) only on base floor;
- Suggest to use 45mm PVC tube for wire resavaion

Capacity (kg)	Speed (m/s)	Cabin outer size A(mm) × B(mm)	Opening size OP(mm) × OPH(mm)	Shaft inner size HW(mm) × HD(mm)	Min. pit depth S(mm)	Min. overhead K(mm)
800	1.0	1200X2050	800X2100 (2P-CO)	2300X2400	2100	4750
	1.5				2250	4900
	1.75				2250	4950
1000	1.0	1400X2100	900X2100 (2P-CO)	2500X2455	2100	4750
	1.5				2250	4900
	1.75				2250	4950

The above figures are for reference only